

**Components and Hardware:**

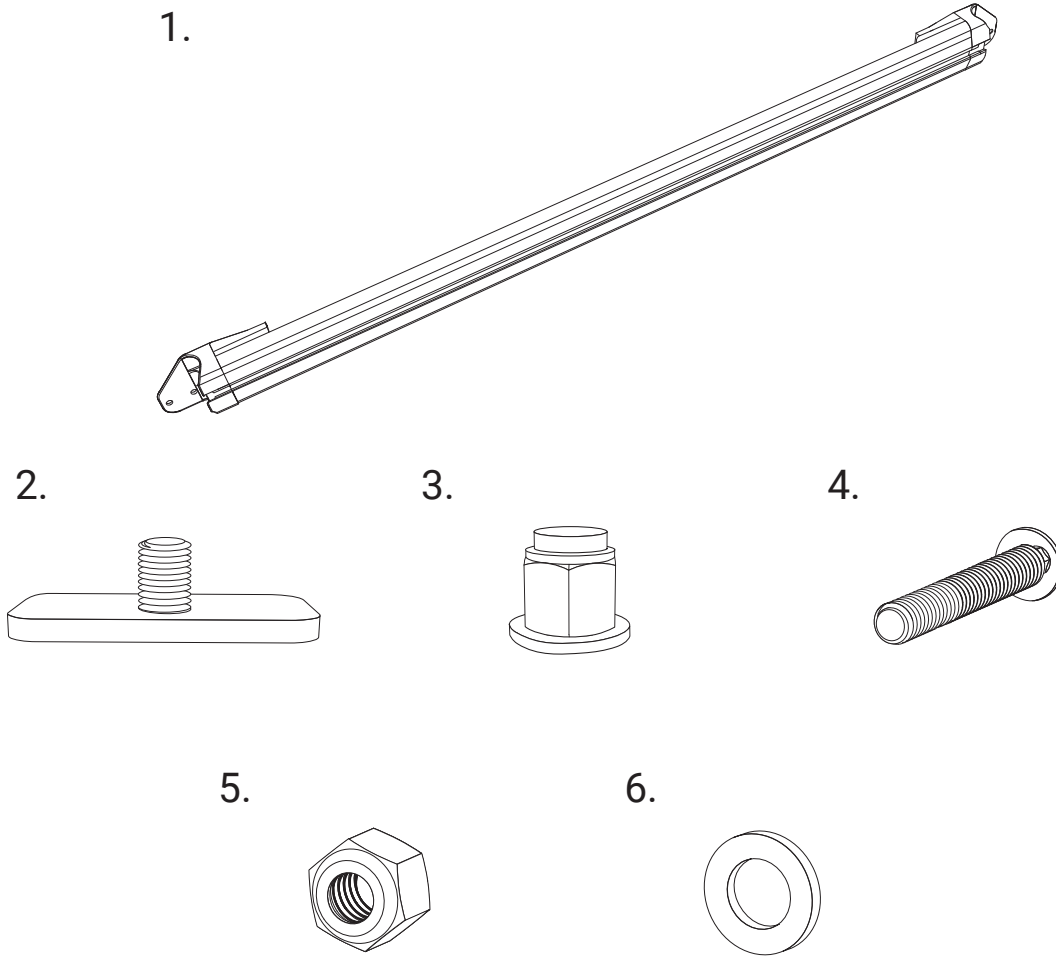

**Components and Hardware:**

- 1. RealTruck Elevate Side Bars..... (2)
- 2. T-Bolts 5/8" (Already installed) ..... (8)
- 3. Cap Nuts 5/16-18 (Already installed) ..... (8)
- 4. Cap Screws 5/16-18 x 2.25" ..... (8)
- 5. Lock Nuts 5/16-18 ..... (8)
- 6. Washers - Diameter 16 x 8 x 0.69" ..... (16)

**Tools for Installation:**

- 1/2" Wrench or Socket
- Scissors or Cutting Tool

## RealTruck Elevate Side Bar Accessory

1. Remove the existing bolts from the uprights and adjust them to the height you want them on both driver and passenger side.

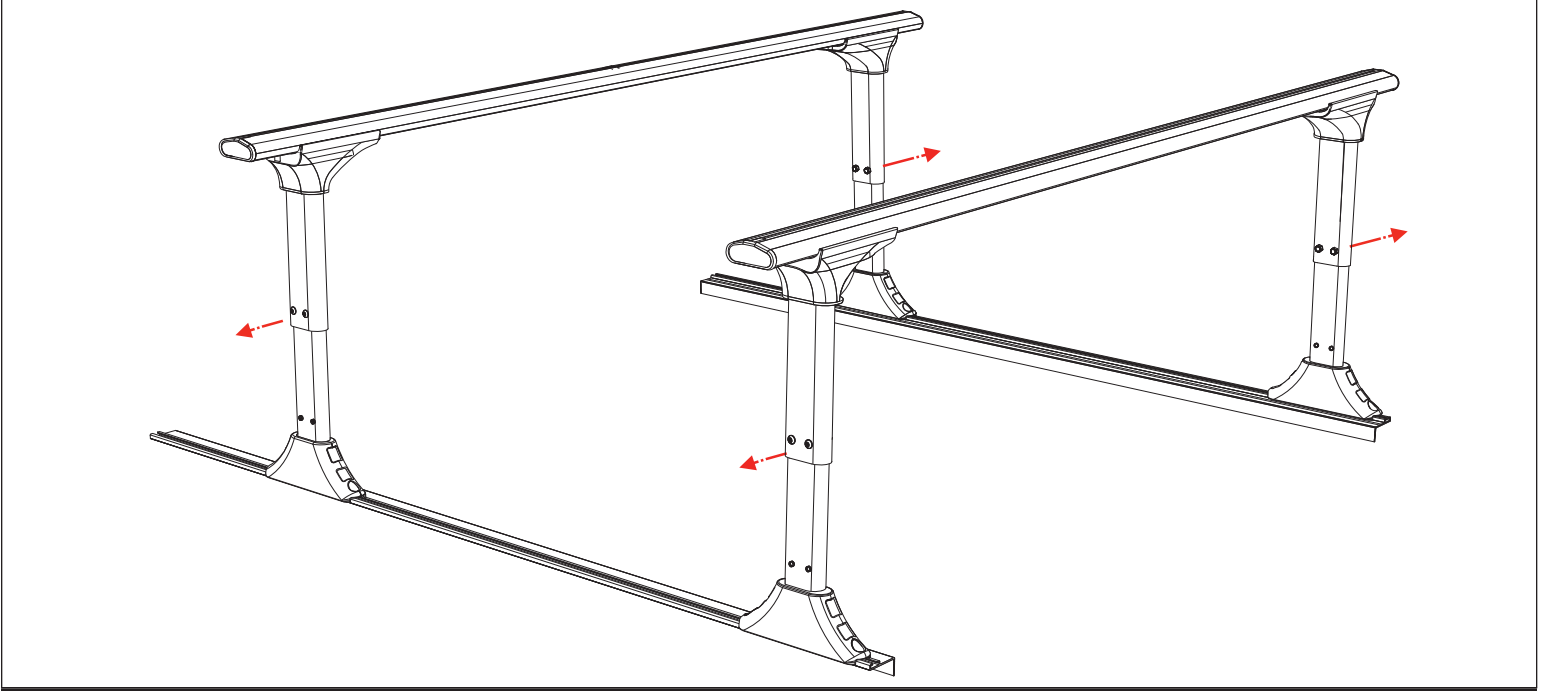

2. Install the Side Bars (#1) to the uprights from the back using 8 Cap Screws (#4), 16 Washers (#6) and 8 Lock Nuts (#5) supplied to accommodate the Side Bars (#1).

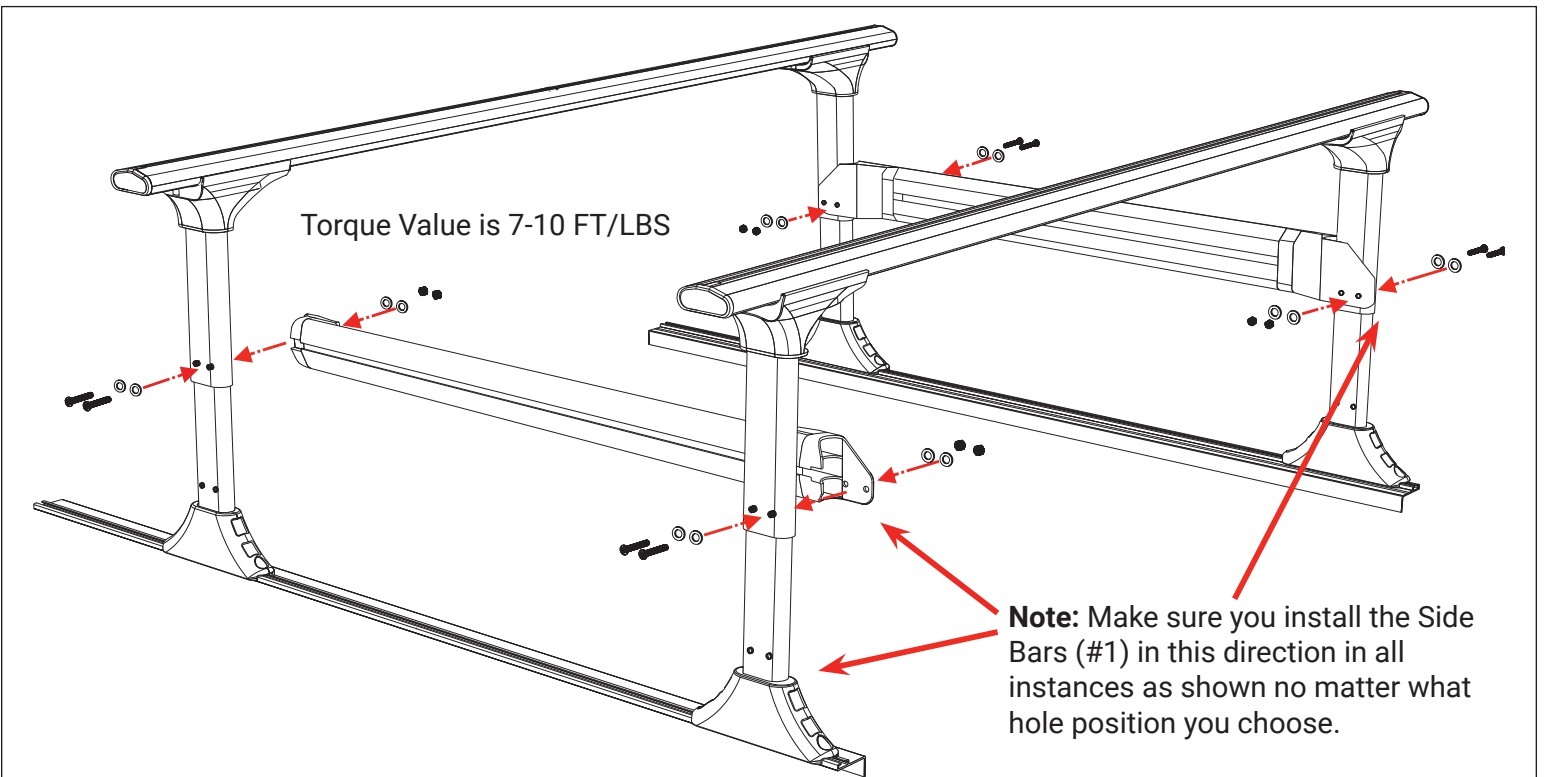

## RealTruck Elevate Side Bar Accessory

### 3. Side Bars (#1) installed.

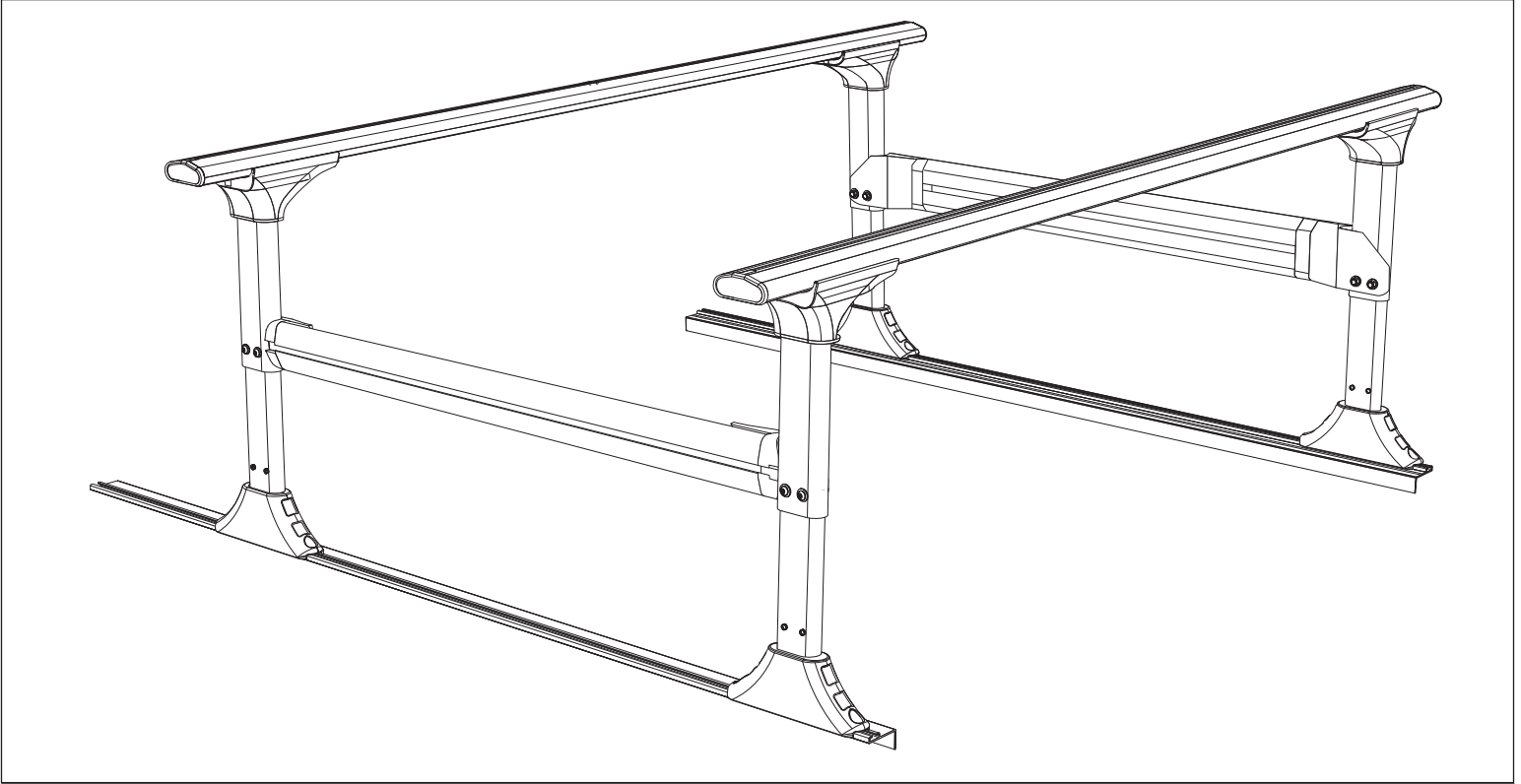

### System Guidelines for RealTruck Elevate Side Bar Accessory

Review all instructions, guidelines, and warranty information before installing or using Elevate Side Bars.

Contact your dealer with any questions regarding proper operation of Elevate Side Bars.

Check state and local laws for compliance with oversized loads.

Adapt speed and care of the vehicle to the load being carried.

Be conscious of load weight, a high center of gravity is a rollover risk.

All loads change the vehicle's driving behavior and responsiveness.

Do not use Elevate Side Bars for anything other than its intended purpose.

Do not exceed the maximum load capacity (load capacity does change by terrain).

Do not drive without the rails properly installed and fasteners torqued to specification.

Know the overall height of every load. Be vigilant of low clearances.

## RealTruck Elevate Side Bar Accessory

### SAFETY INSTRUCTIONS

Elevate TS Rails and Side Bars work with most inside mount truck bed covers.

All mounting fasteners must be securely tightened before operation.

Elevate Side Bars do NOT increase the load rating of the vehicle.

### OWNER/USER RESPONSIBILITIES

It is the responsibility of the owner/user to read this manual and comply with the operating procedures. The owner/user is also responsible for inspecting the Elevate TS Rails and Side Bars, and for having parts repaired or replaced when worn or damaged.

Failure to follow safety instructions and warning labels could result in failure of your Elevate TS Rails and Side Bars and/or personal injury.

### CARE & MAINTENANCE

Elevate Side Bars can be hand washed with soap and water.

### ELEVATE RACK & SIDE BAR LOAD RATING

Elevate Racks are rated for 750 lbs. static weight capacity (max. load in a fixed or stationary position), 500 lbs. on-road weight capacity and 250 lbs. off-road weight capacity distributed across all components of the Elevate Rack System. Maximum weight on side bars: 120lbs.