

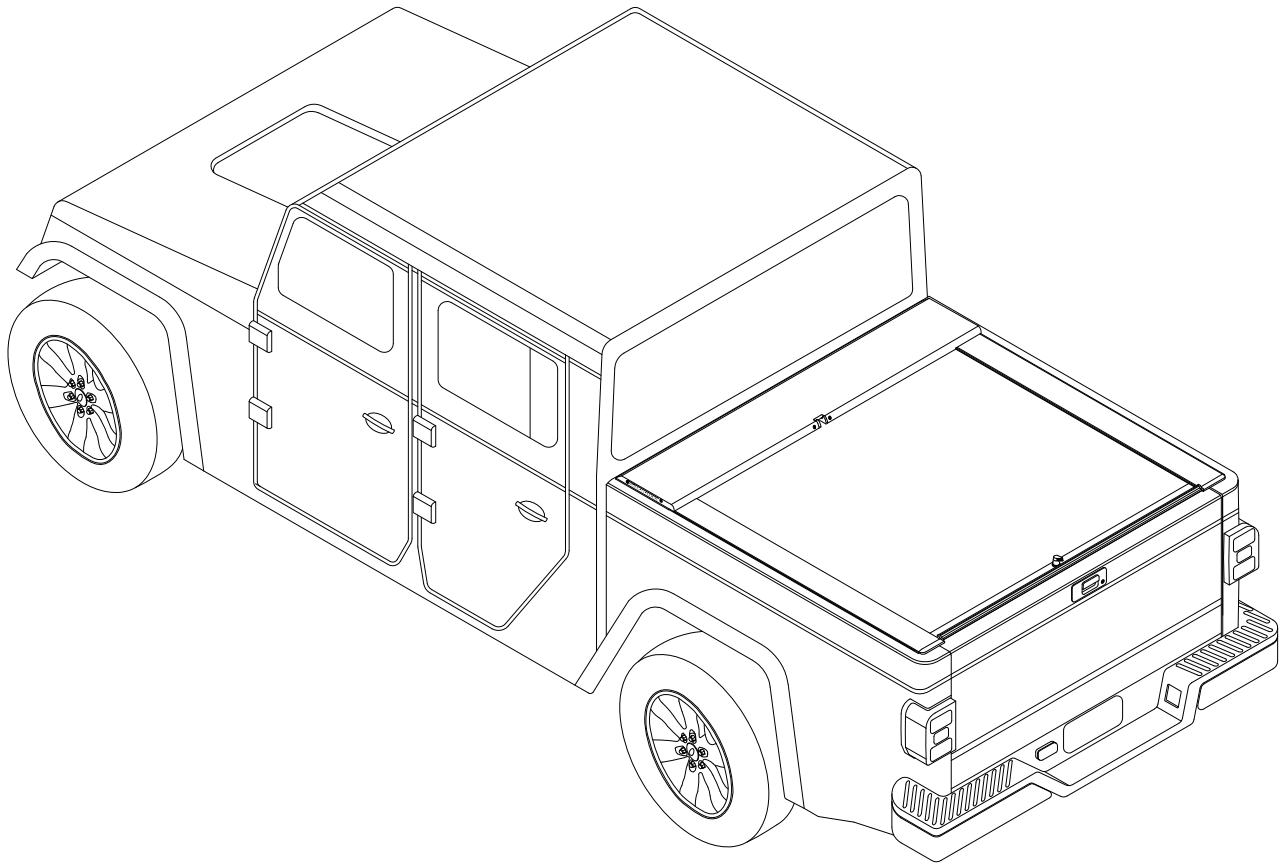

Installation Guide

Jeep Gladiator



Product Code
495

Parts List

Item	Part Name	Qty.	Item	Part Name	Qty.	Item	Part Name	Qty.
A	Housing	1	G	Leveling Shim	2	M	5/16" Flat Washer	4
B	Track	2	H	#8 x 3/4" Self Tap Screw	2	N	Allen Wrench (1/4")	1
C	Cargo Shield	1	I	#10-24 Screw	2	O	1/4-20 x 3/8" Screw	4
D	Bulkhead Flashing	1	J	Cargo Nut	2	P	Rubber Washer	4
E	Threaded Block	4	K	5/16" Socket Cap Screw	4	Q	1/4" Lid Screws	2
F	Width Adjustment Shim	2	L	5/16" Lock Washer	4	R	Drain Tube	2
							303 Vinyl Protector	1

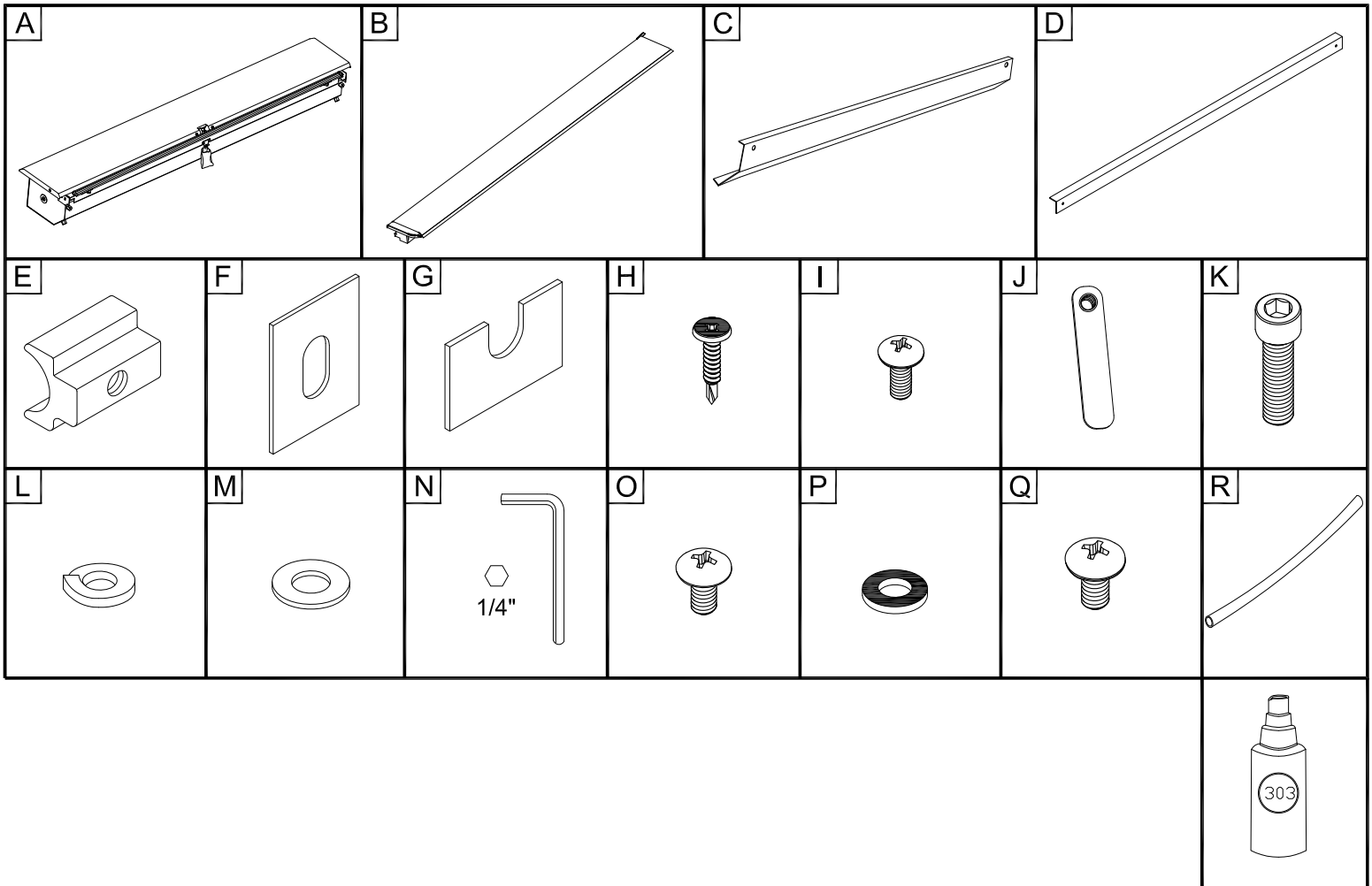

Tools Needed

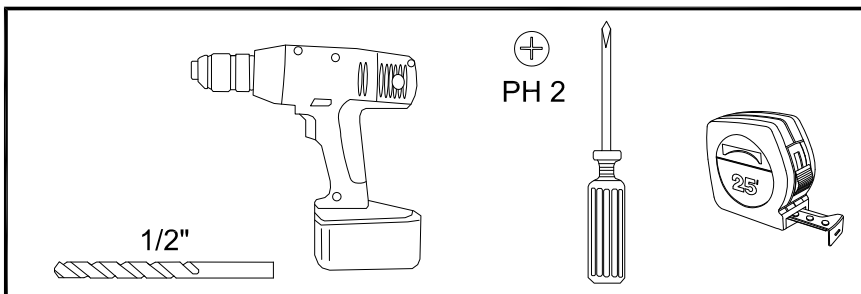

1a

If no plastic bedliner present proceed to page 4

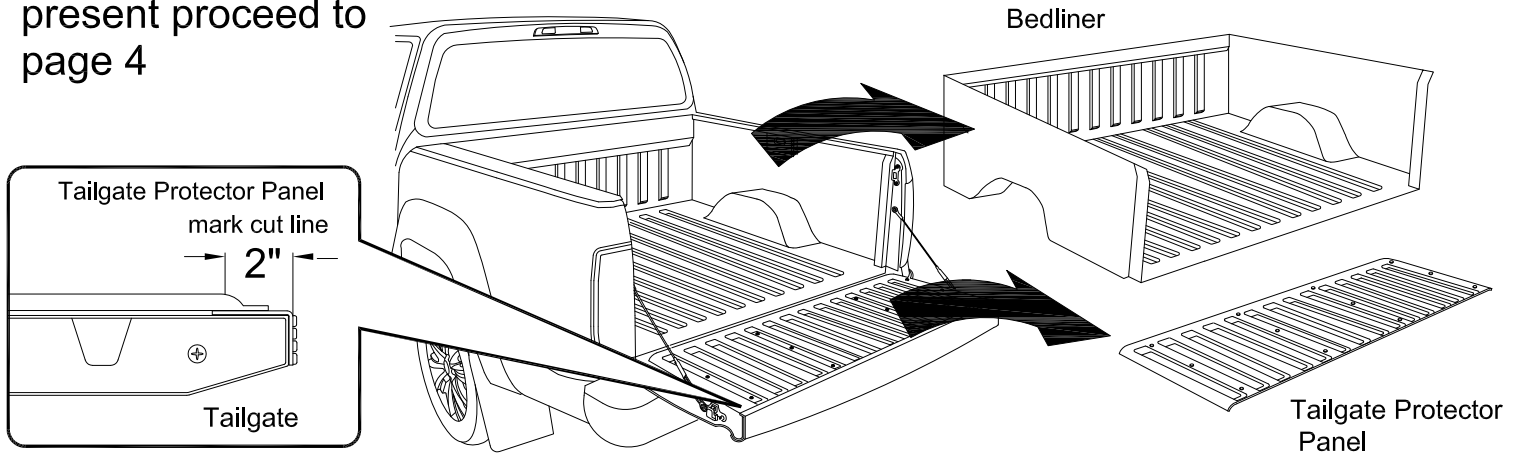

1b

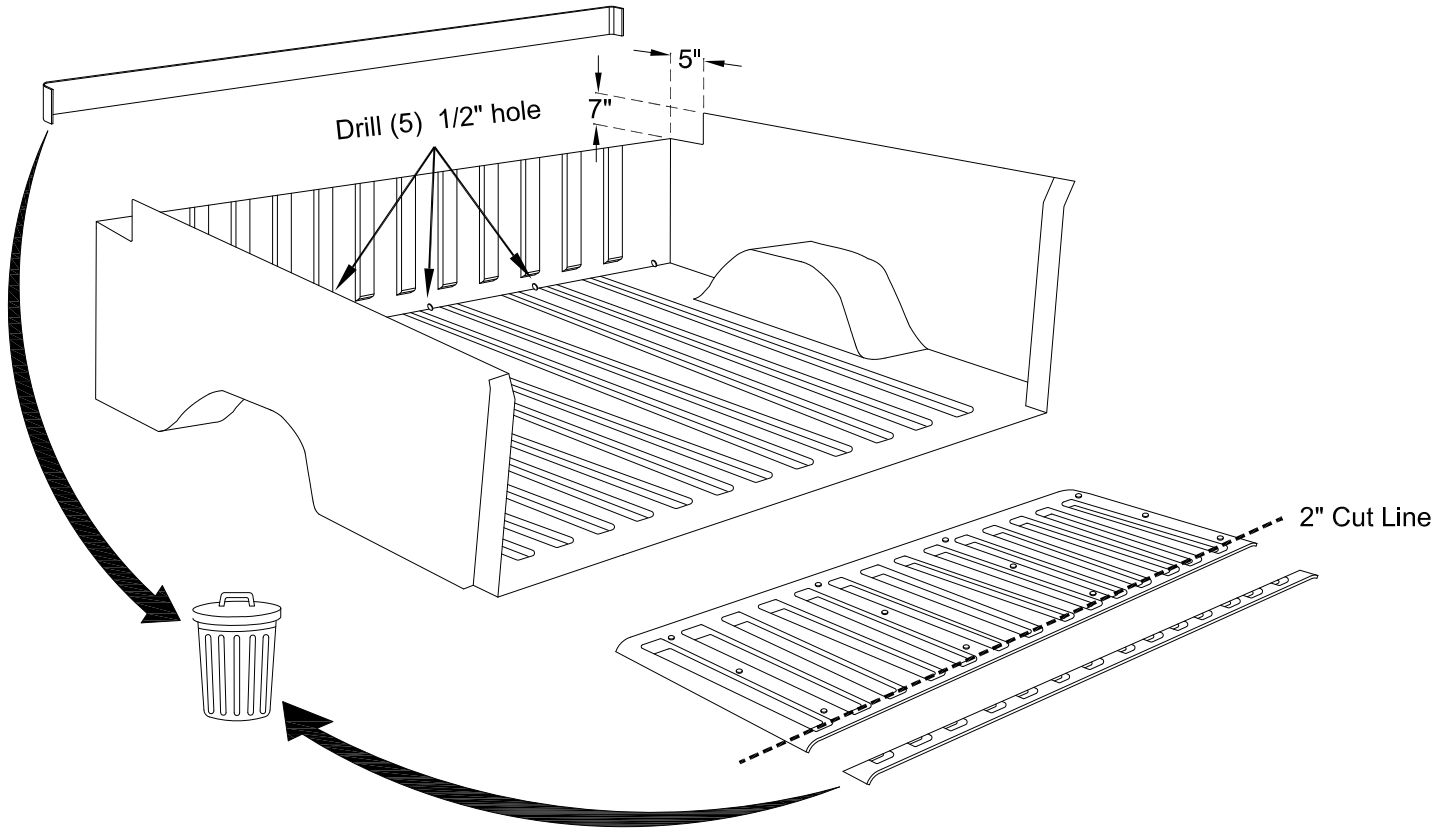

1c

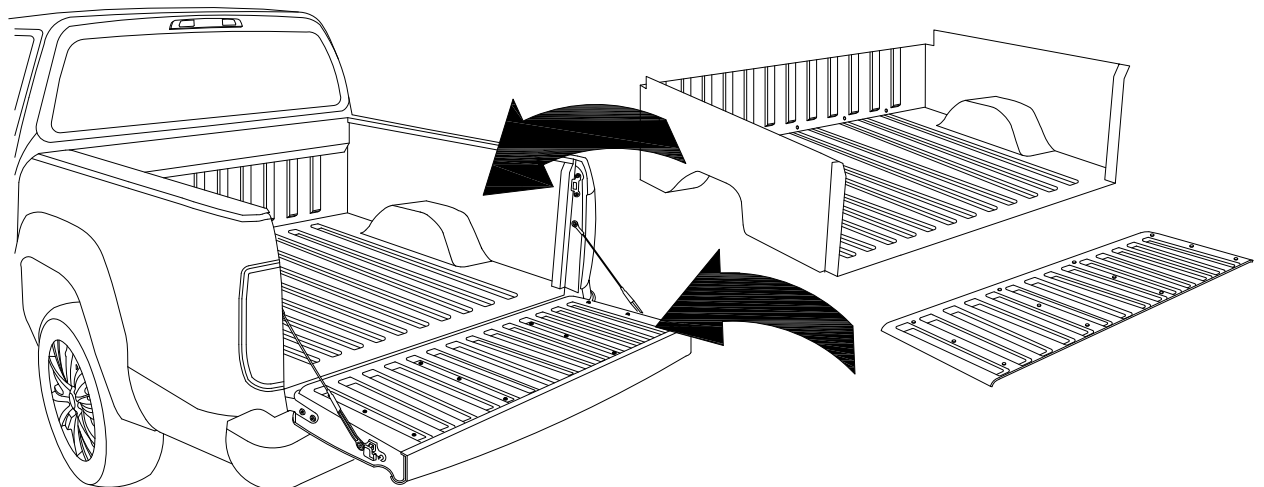

1

Remove channel on bulkhead only.

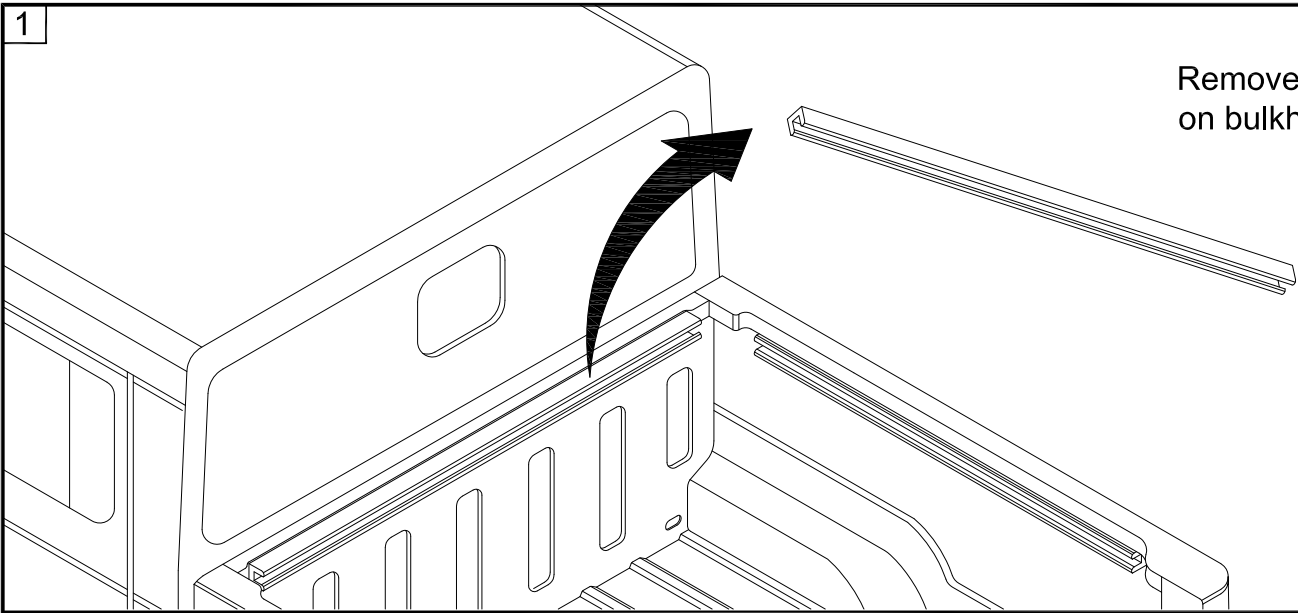

2

1. Peel backing from tape and stick flashing onto bulkhead.
2. If needed use self tapping screw (H) to secure flashing at each end.
3. Note flashing orientation.

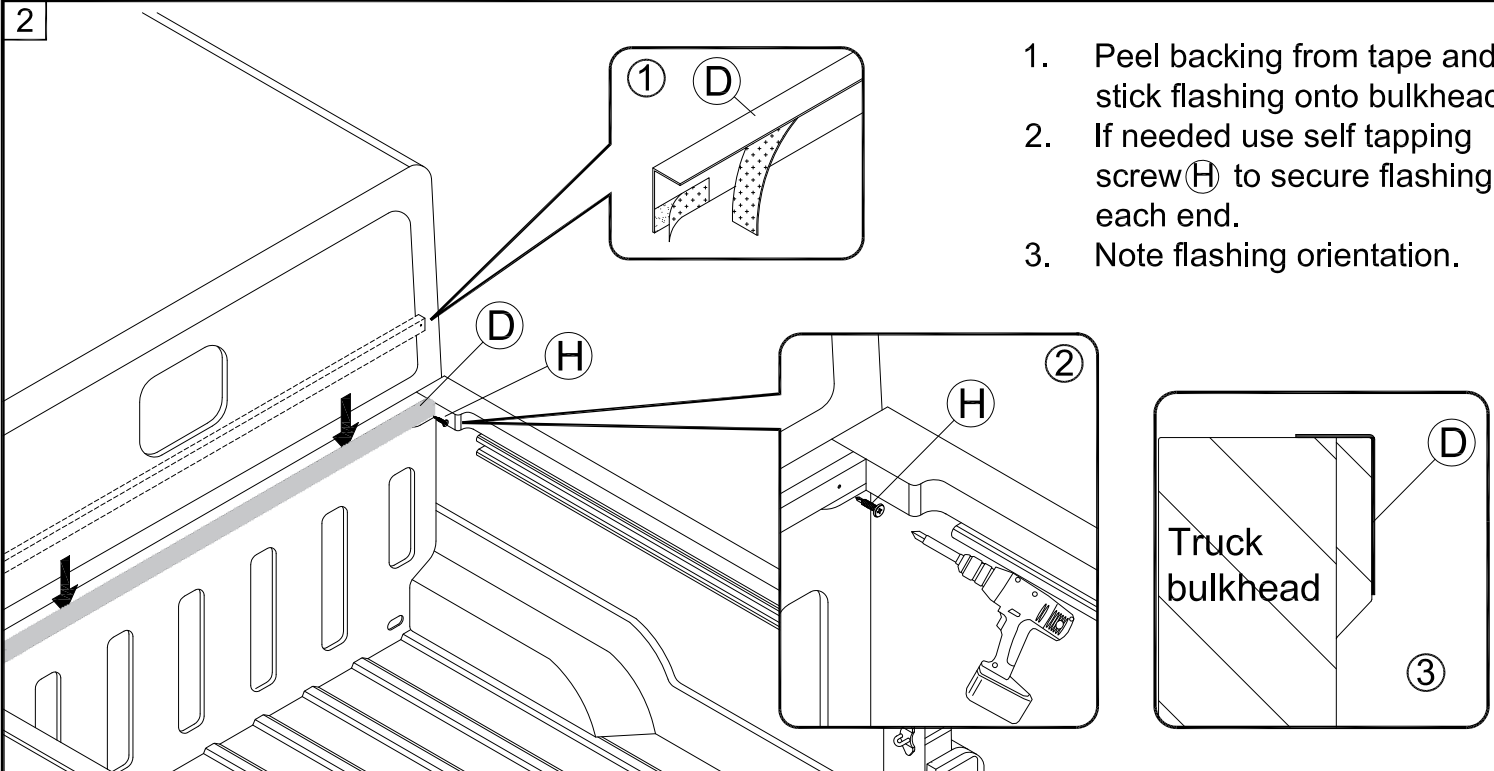

3 LHS = RHS

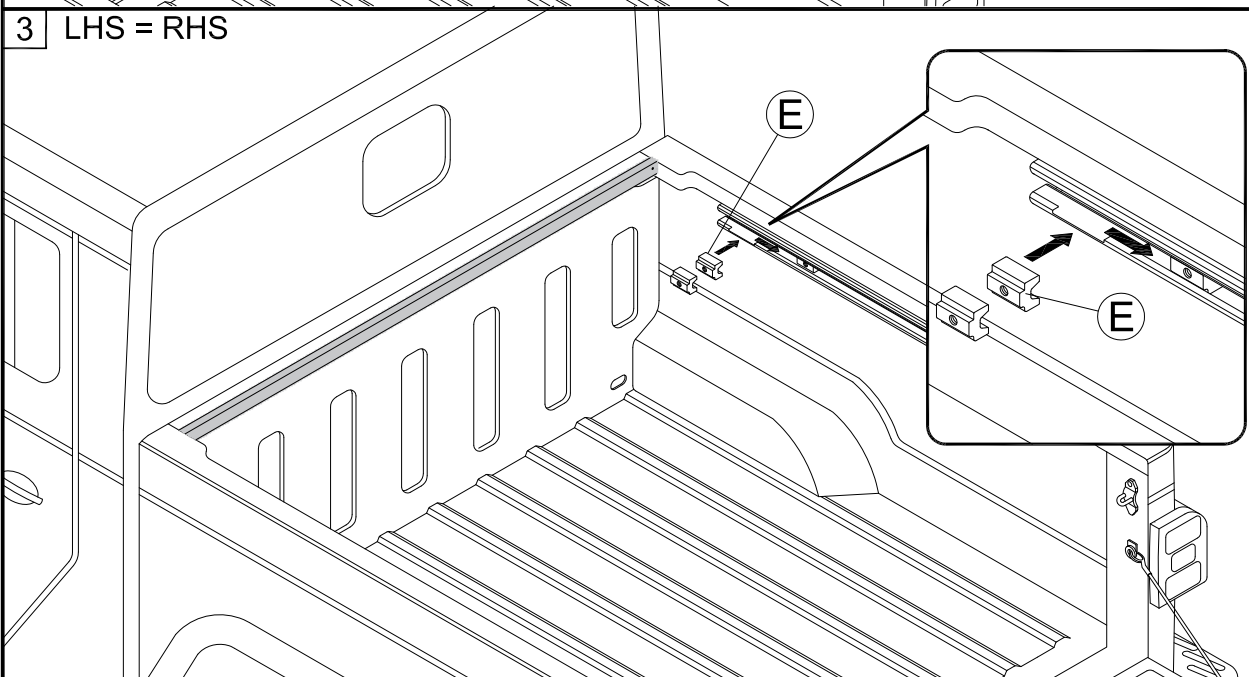

Insert two Threaded Blocks (E) into the channel.

4

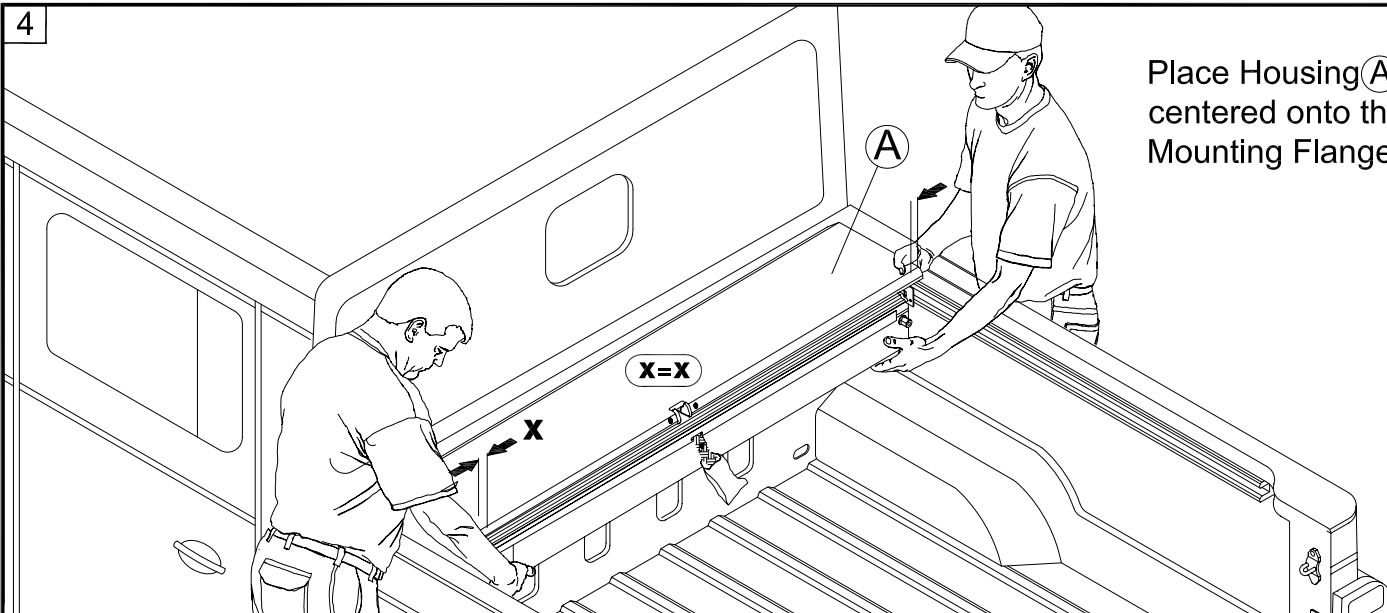

Place Housing (A) assembly centered onto the Track Mounting Flanges.

5 LHS = RHS

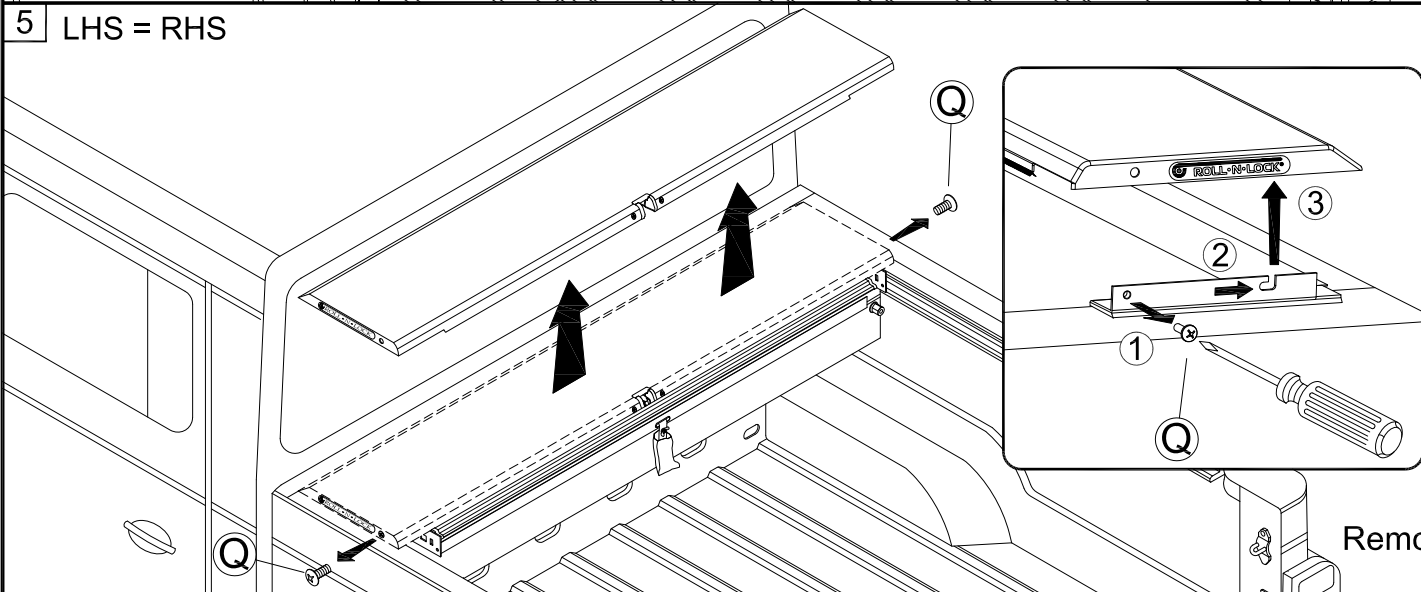

Remove lid.

6 LHS = RHS

Turn lock to 10 o'clock and key Tracks onto housing stems. Do not remove pull strap.

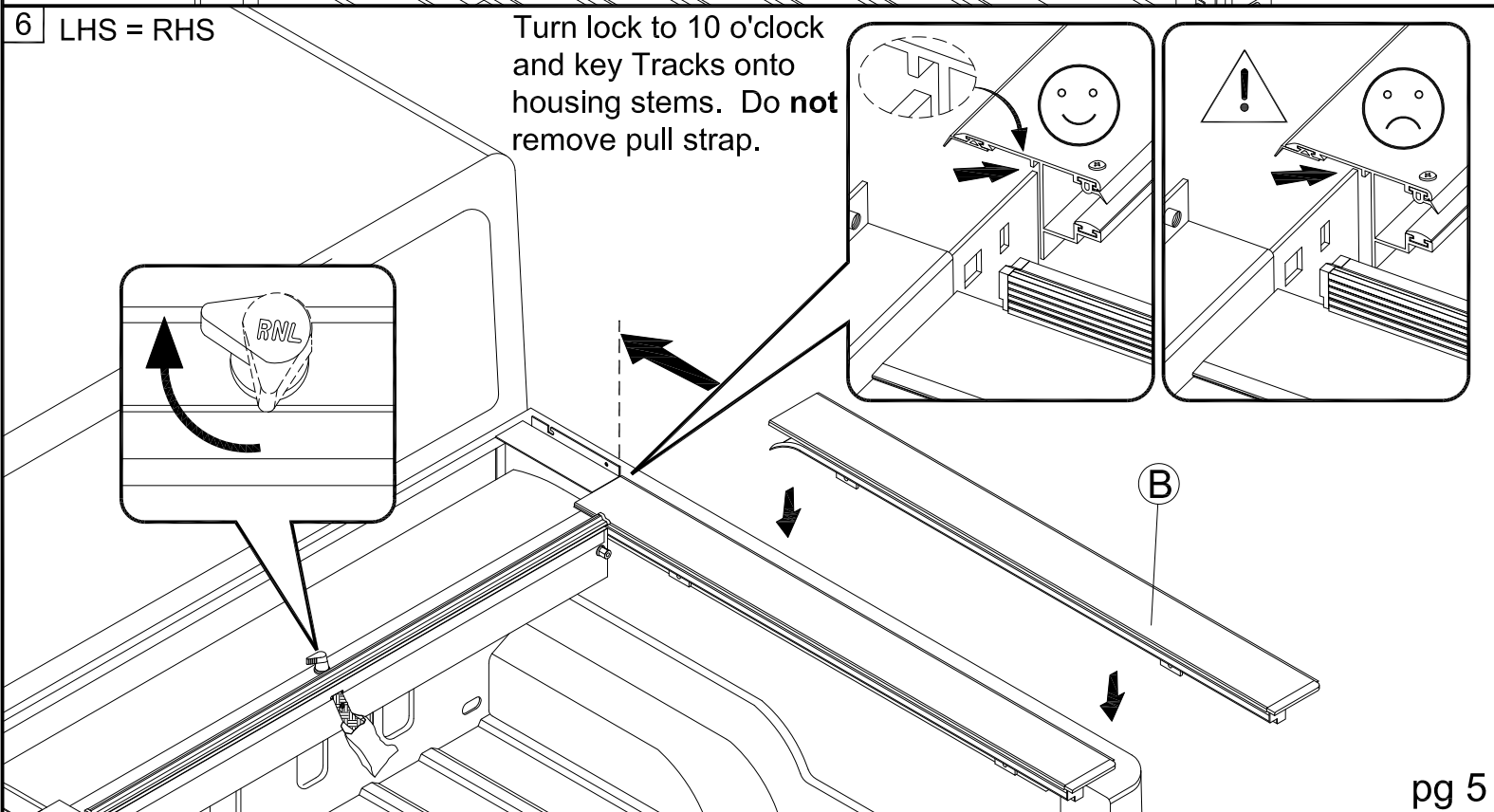

7 LHS = RHS

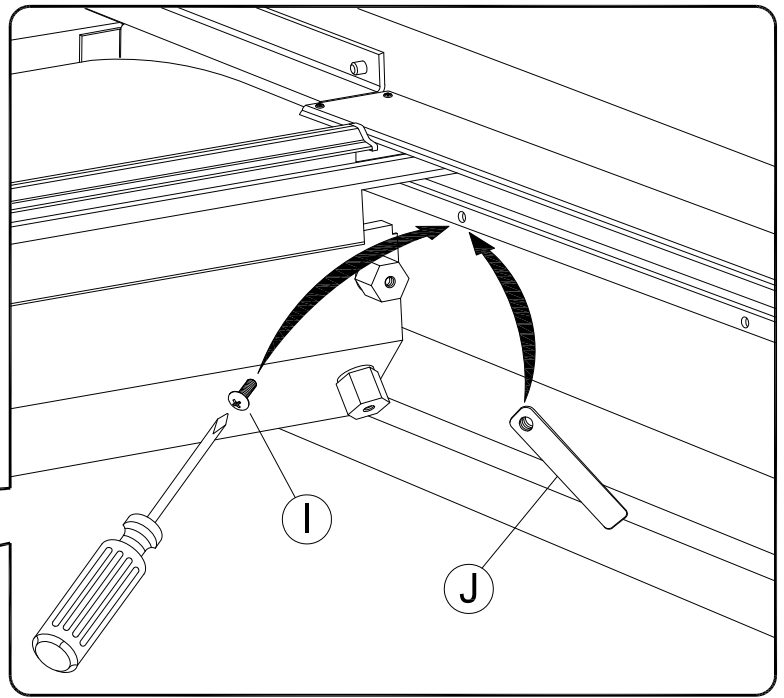
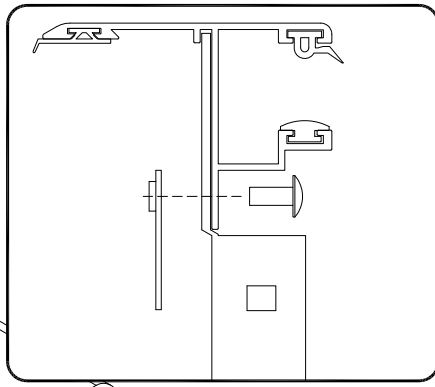

Secure Tracks to housing stems.

8 LHS = RHS

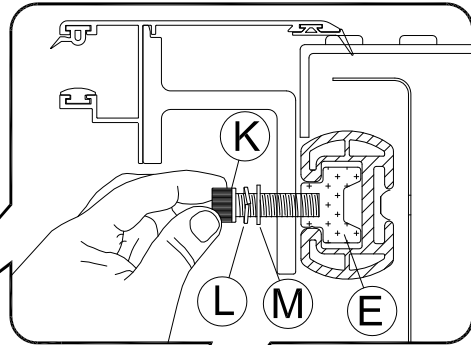

K
L
M

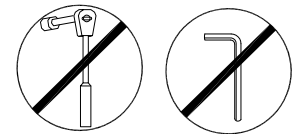

Loosely attach the track with the cap screw (K) and washers (L) (M) to the threaded block (E).

9 LHS = RHS

Carefully close tailgate, shift the housing back so the end of the tracks are up against the tailgate.

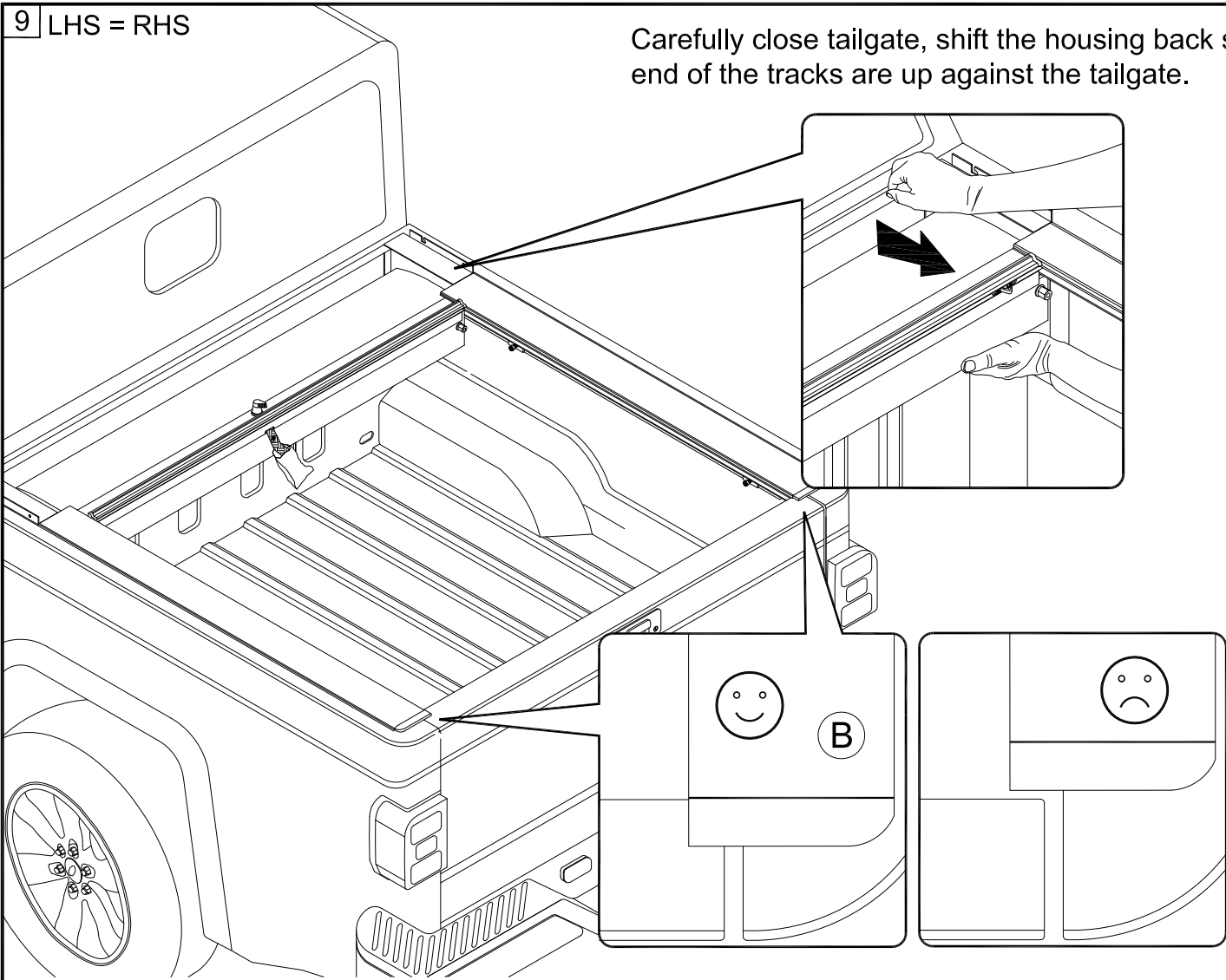

10

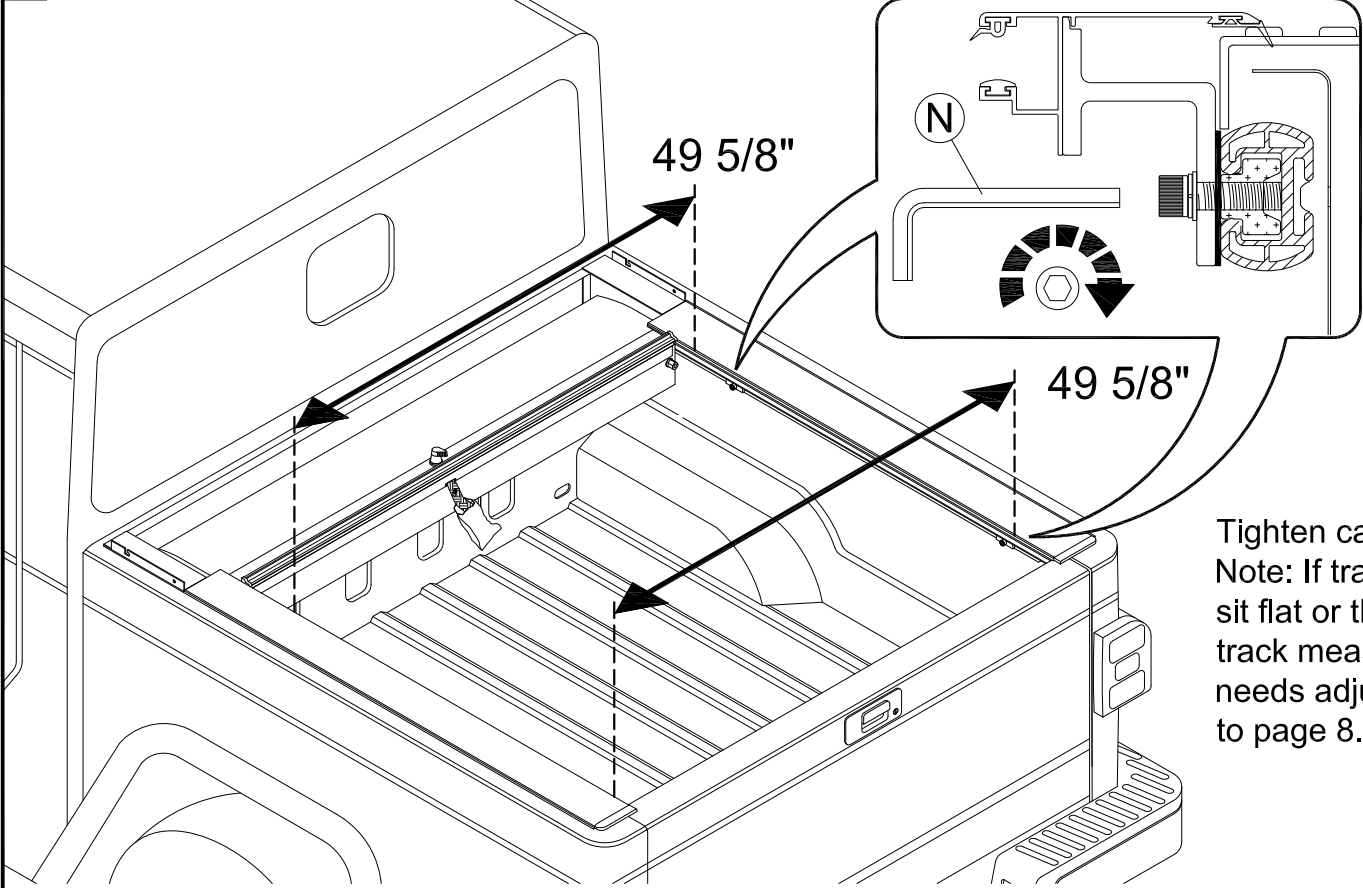

Tighten cap screws.
Note: If track does not sit flat or the track to track measurement needs adjustment refer to page 8.

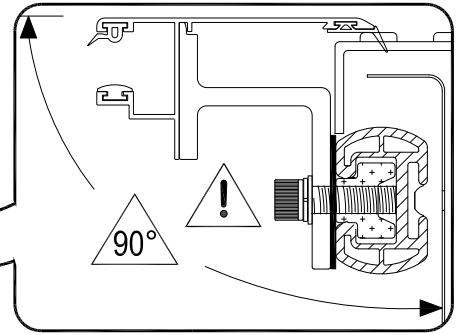
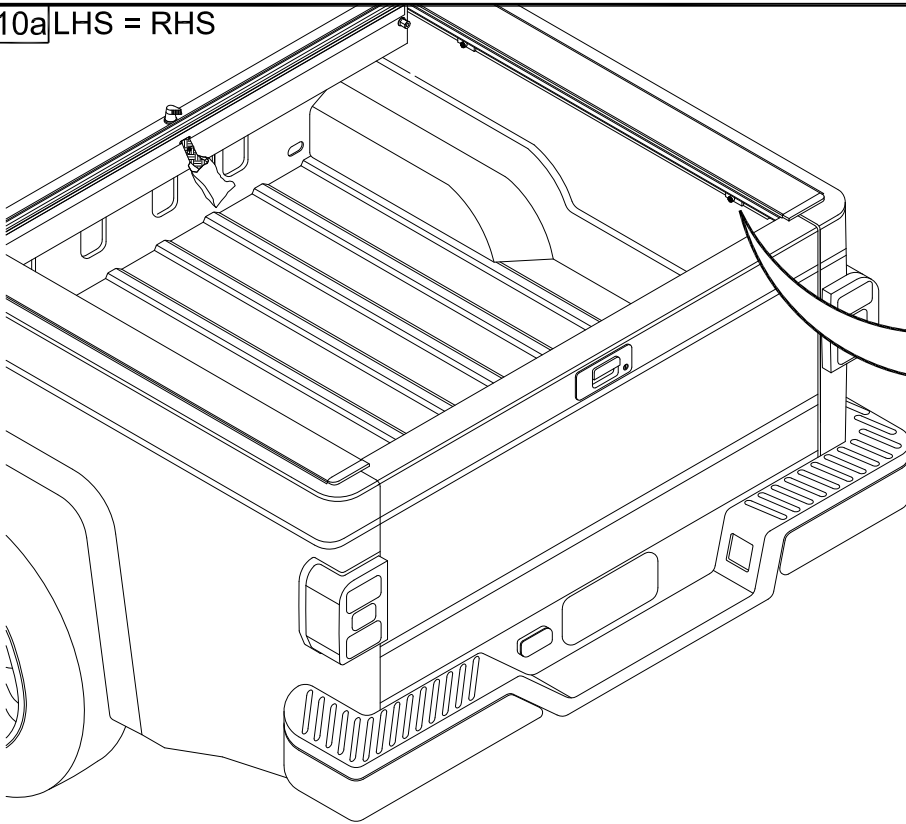

Follow the steps below as needed.

Track tips up or down.

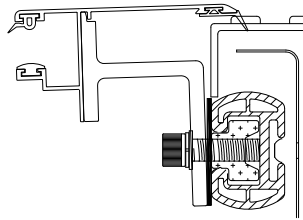

Insert leveling shim(s) **G** behind clamp(s) at tailgate as needed.

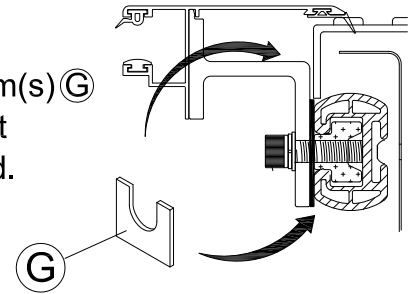

Track to Track is <(less than) 49 5/8".

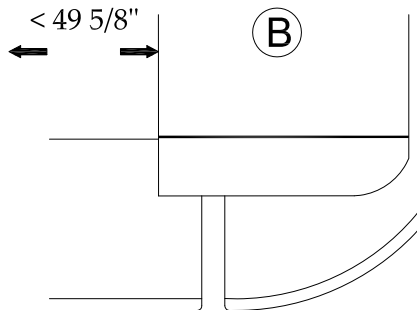

Remove existing shim(s). May need to replace with thinner supplied shim(s) **F**.

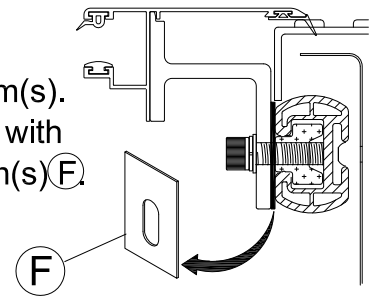

Track to Track is >(greater than) 49 5/8".

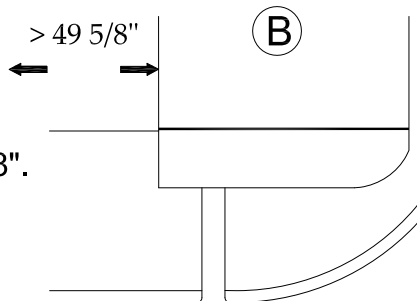

Add width adjustment shim(s) **F** as needed.

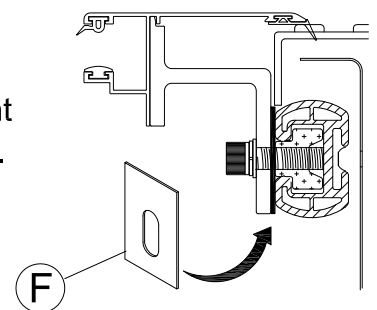

11

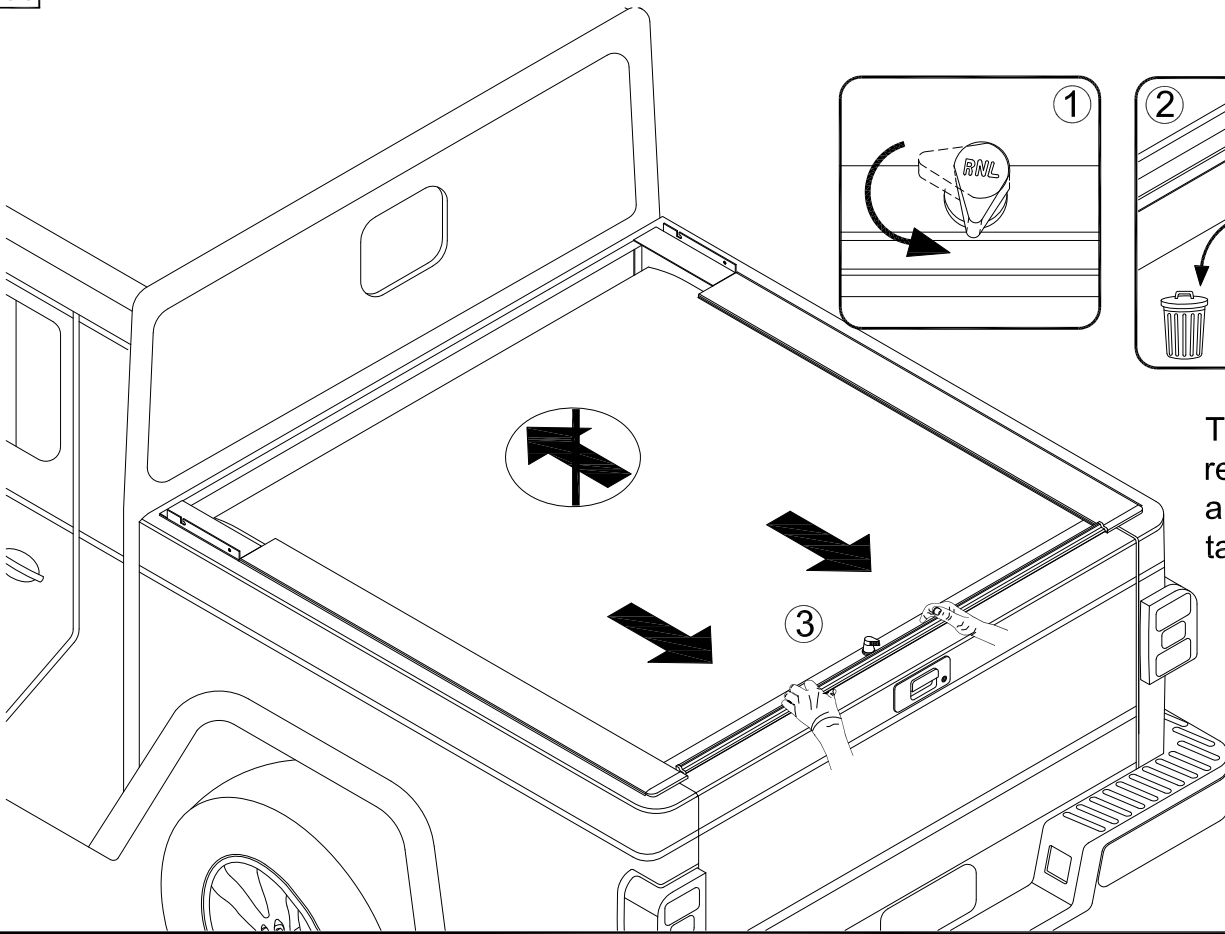

Turn lock to 7 o'clock, remove plastic wing nut and pull cover back to tailgate.

12

Replace lid.

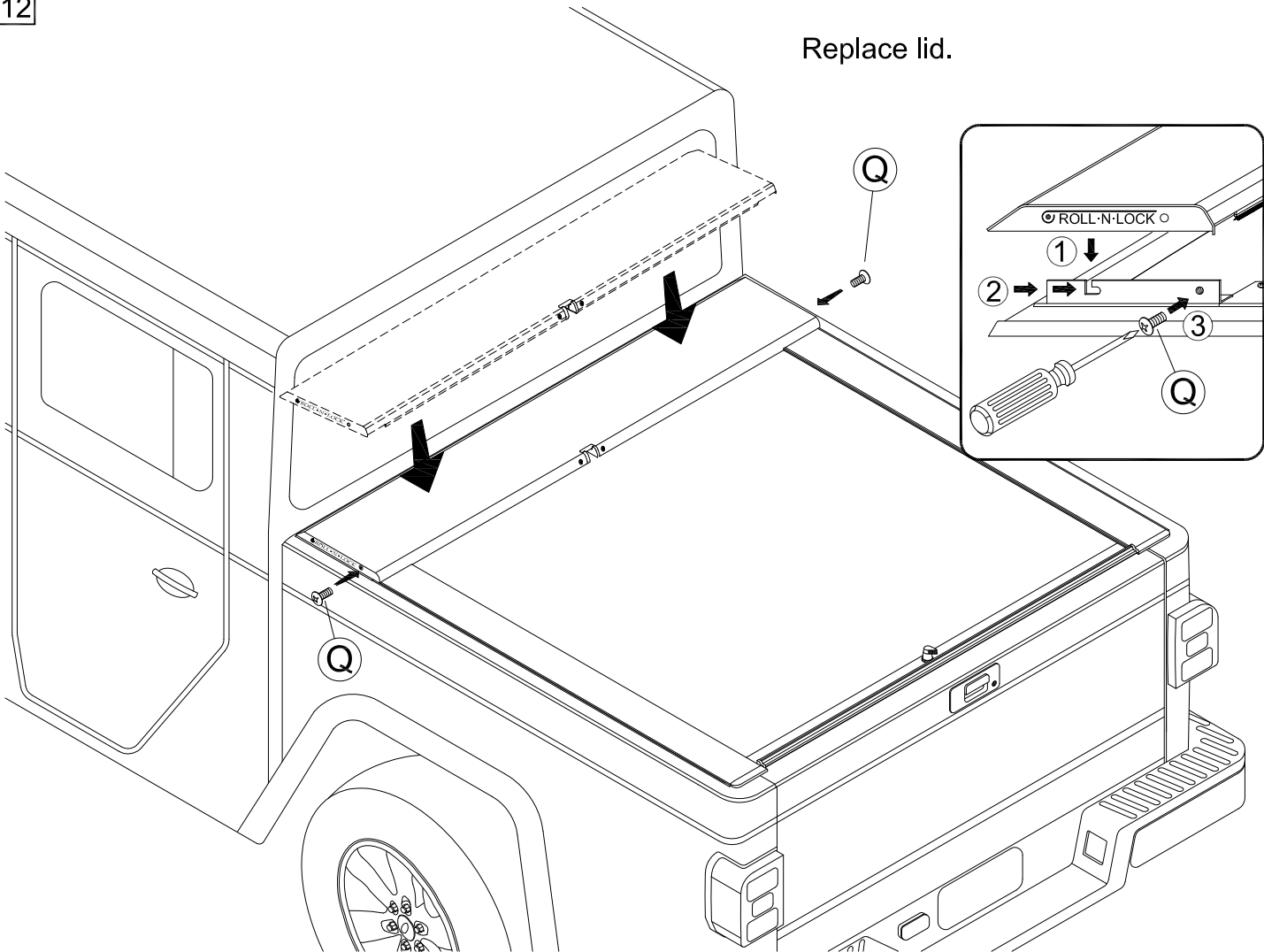

13

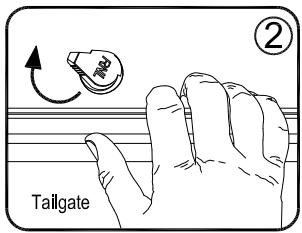
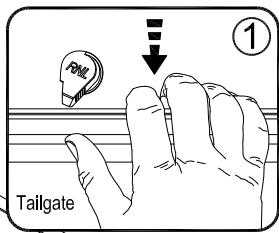
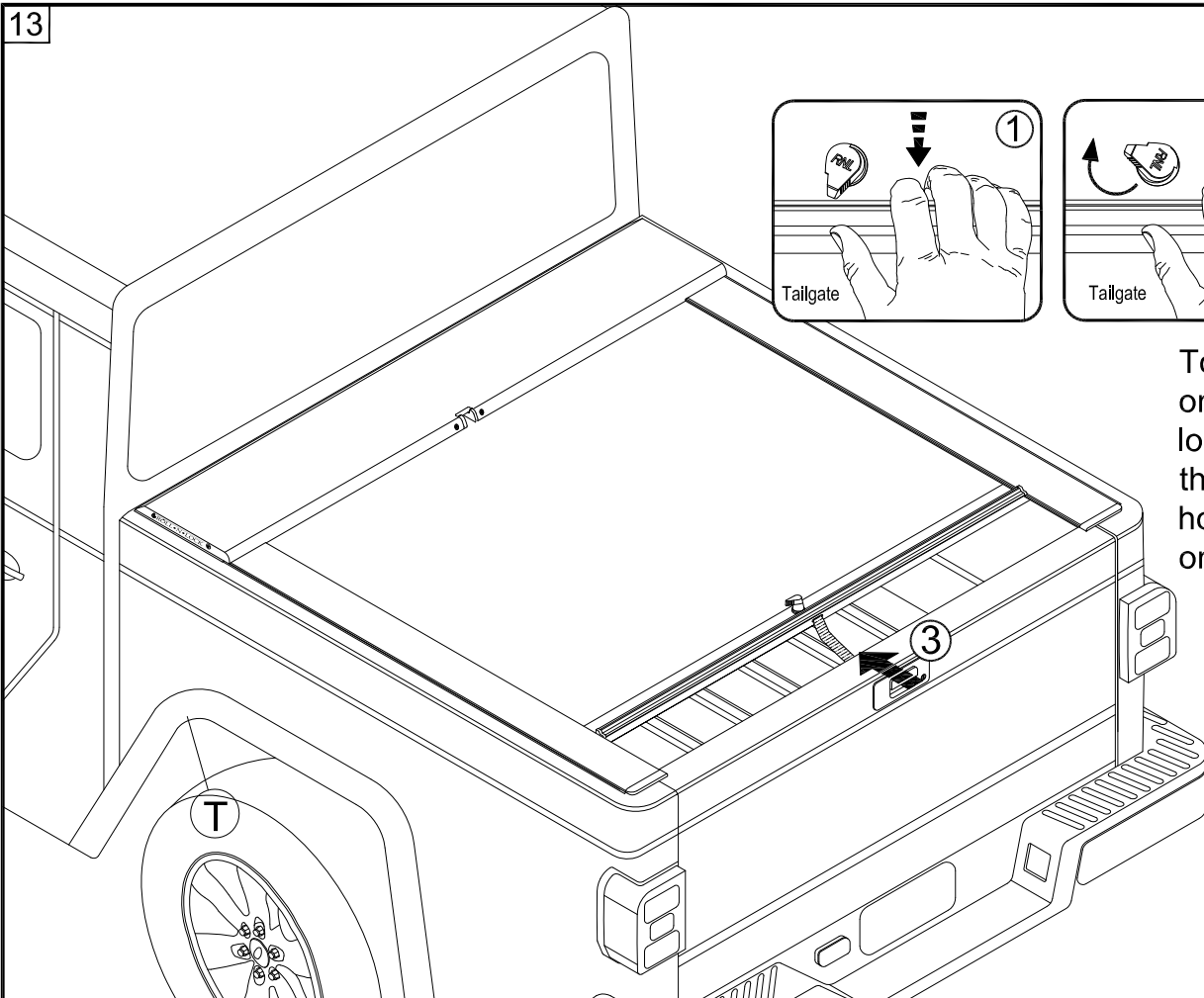

To open cover pull back on the handle, turn the lock to 10 o'clock and let the cover retract into the housing while holding onto the pull-strap.

14 LHS = RHS

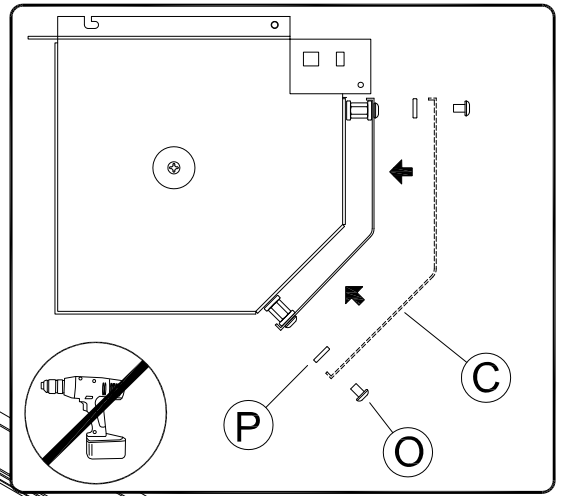
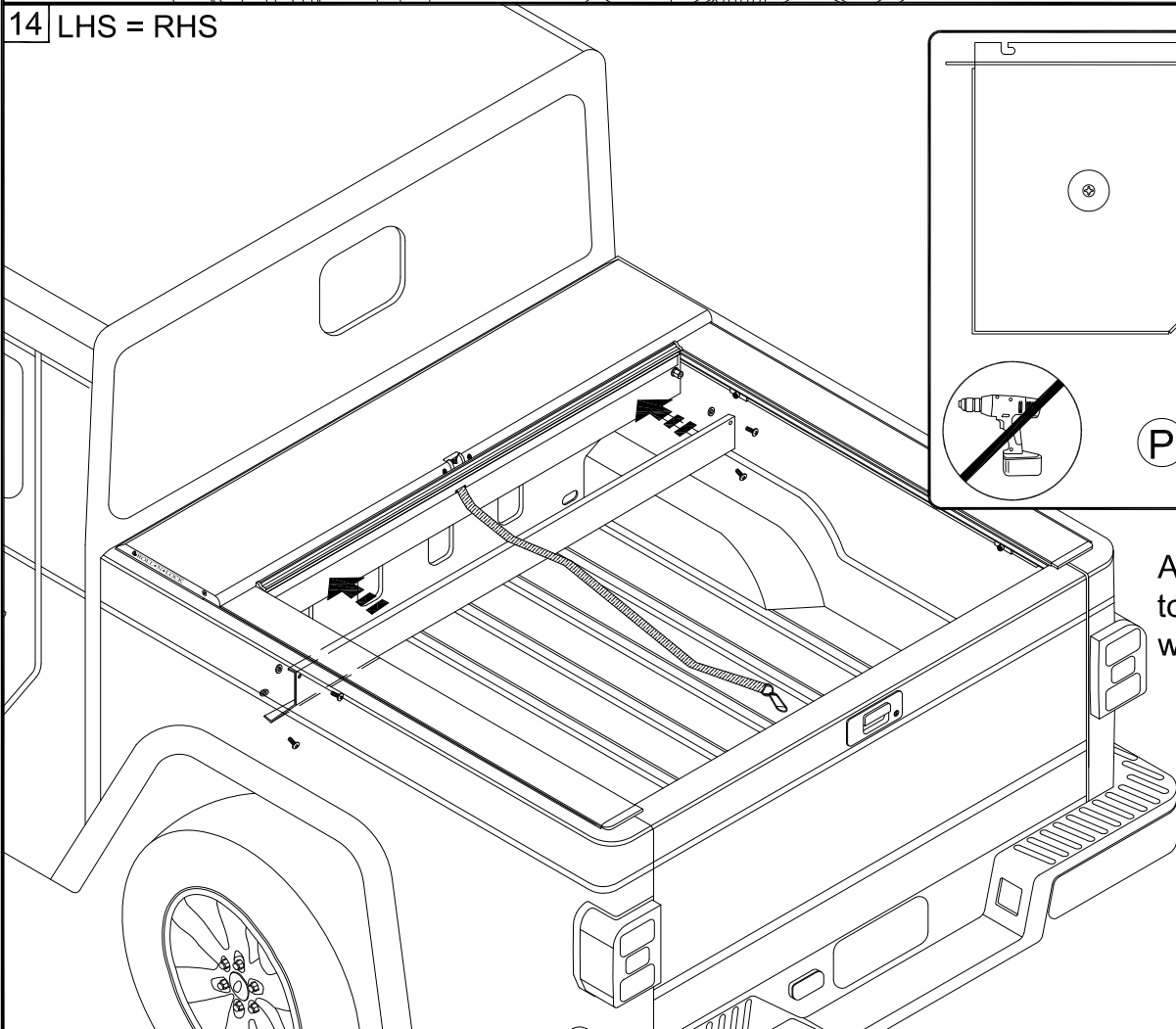

Attach the Cargo Shield[©] to the housing. Note washer[Ⓟ] placement.

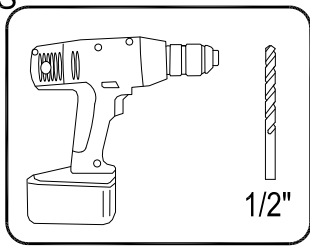

Drill 1/2" hole and insert one end of the Drain Tube® through and insert the other end onto the drain stem.

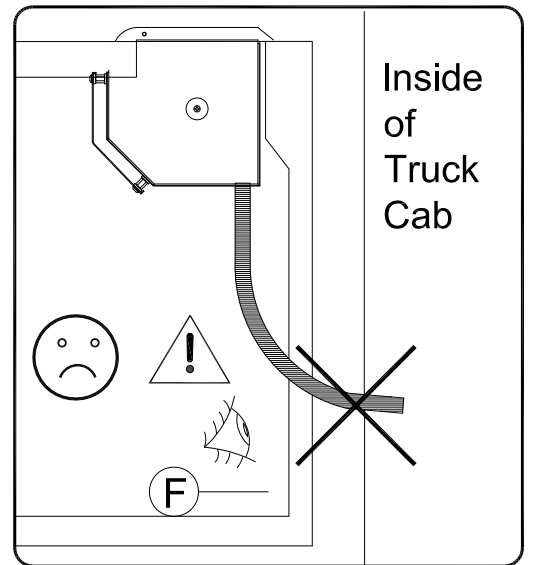
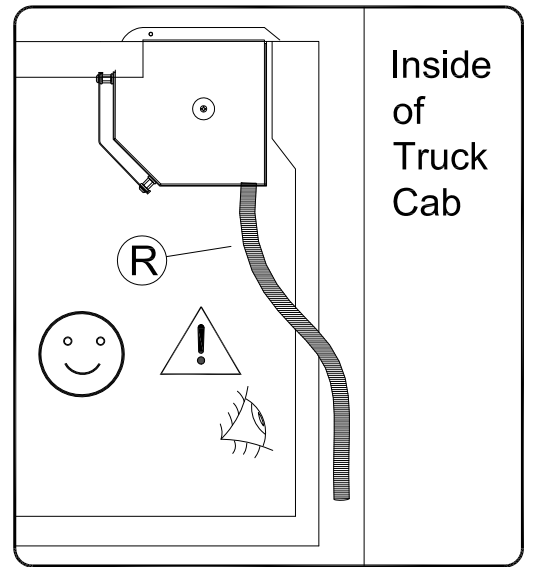
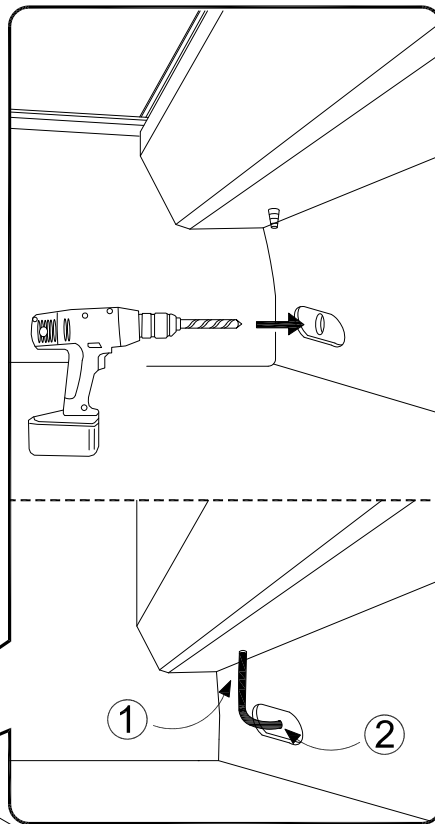

Clip pull strap to truck.

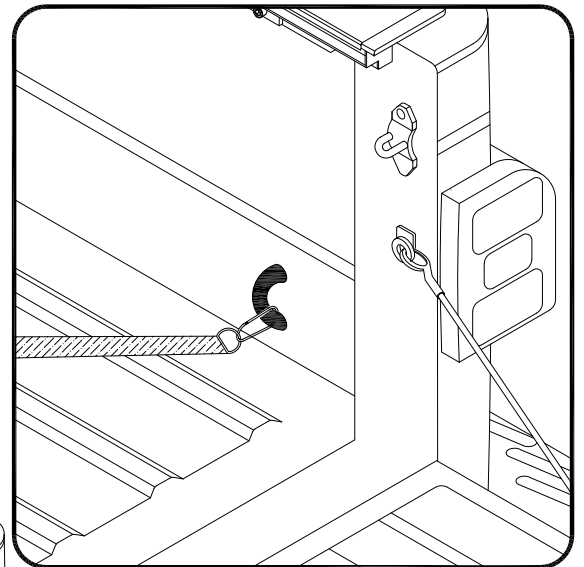
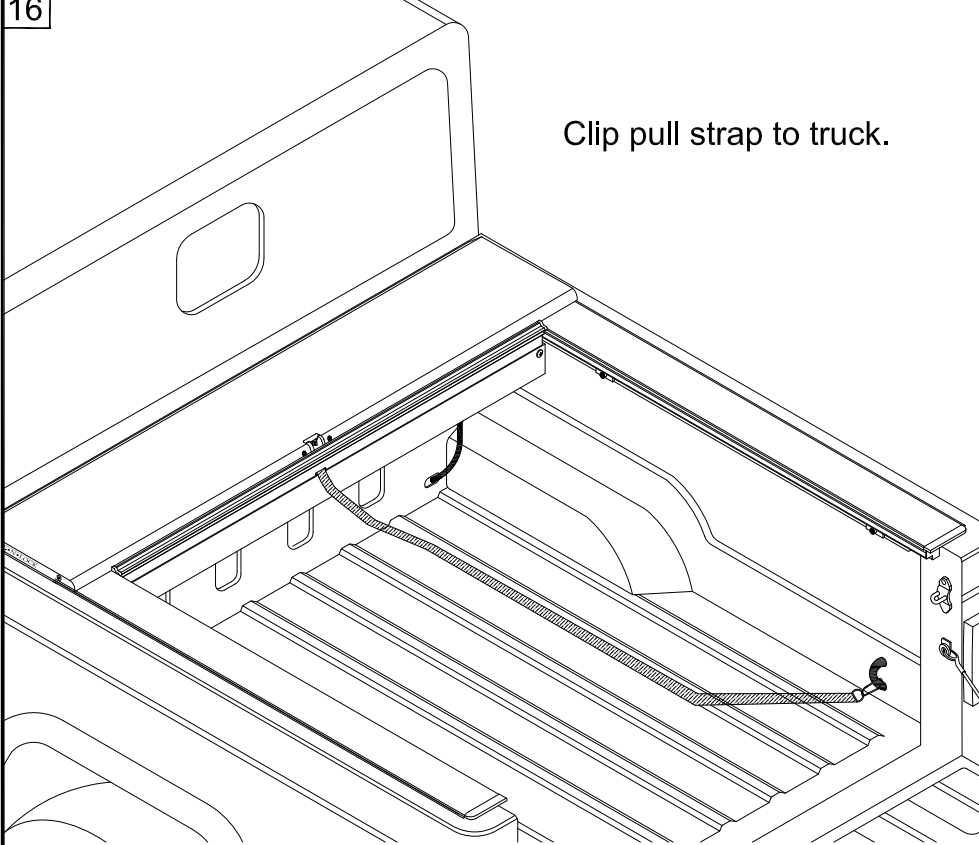

Troubleshooting

Cover is hard to pull or retract.



Spray 303[®] on a rag and wipe the top gasket in the Track back and forth.

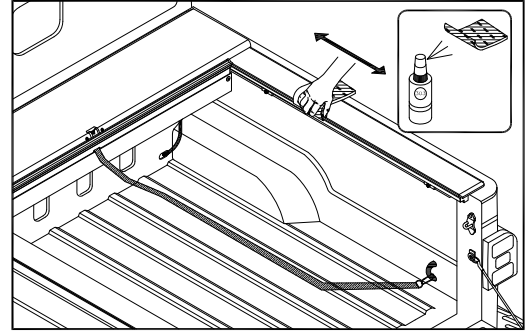

Cover does not latch.



Check track to track measurement.

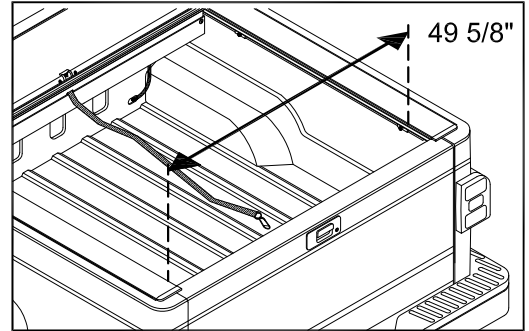

Cover does reach tailgate.



Make sure Tracks are back against tailgate.

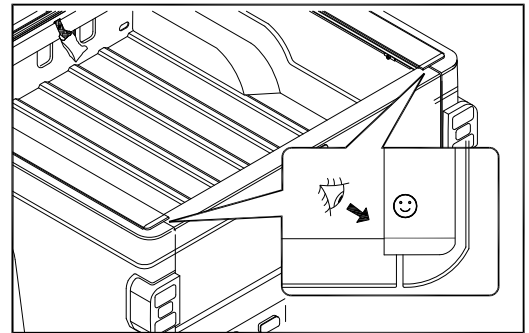

Track tips up or down.



Add shim as needed.

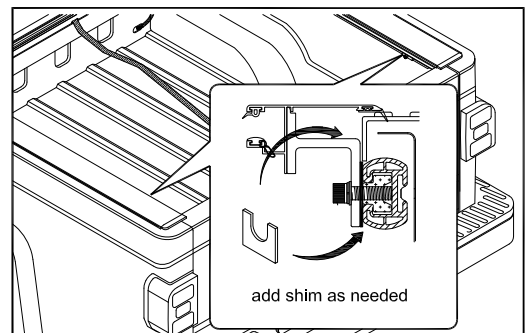

Any questions please call Customer Service at 800-952-7655
or email customerservice@rollnlock.com