

INSTALLATION MANUAL

13481

Level of Difficulty

Easy

Installation difficulty levels are based on time and effort involved and may vary depending on the installer level of expertise, condition of the vehicle and proper tools and equipment.

Weight Carrying Capacity

Gross trailer weight (GTW)	6,000 lbs.
Tongue weight (TW)	900 lbs.

Parts List

Item	Qty	Description
1	4	Carriage bolt, 1/2"-13 x 1-1/2", grade 8
2	4	Serrated-flange nut, 1/2"-13, grade 8
3	4	Square hole spacer, 1/4" x 1" x 3"

Tools Required

Ratchet	Tape measure
Socket, 3/4"	Torx bit, T-15
Torque wrench	Tape
Fishwire, 1/2" (includes 4 qty)	Rotary cutting tool or Reciprocating saw

* For a tools reference guide visit curtmfg.com/trailer-hitch-installation

⚠ WARNING

Never exceed the vehicle manufacturer's recommended towing capacity.

Product Photo



NOTICE

Visit www.curtmfg.com for a full-color copy of this instruction manual, as well as helpful videos, guides and much more!

Before you begin installation, read all instructions thoroughly.

Proper tools will improve the quality of installation and reduce the time required.

This installation requires:

- Trimming of the bumper fascia
- No drilling

Periodic inspection of the trailer hitch should be performed to ensure all mounting hardware remains tight and structural components are secure.

To help prevent damage to the product or vehicle, refer to the specified torque specifications when securing hardware during the installation process.

SAFETY INSTRUCTIONS

Safety glasses should be worn at all times while installing this product.

Product Registration and Warranty

CURT stands behind our products with industry-leading warranties. To get copies of the product warranties, register your purchase or provide feedback, visit: warranty.curtgroup.com/surveys

ASSEMBLY

Parts List

Item	Qty	Description
1	4	Carriage bolt, 1/2"-13 x 1-1/2", grade 8
2	4	Serrated-flange nut, 1/2"-13, grade 8
3	4	Square hole spacer, 1/4" x 1" x 3"

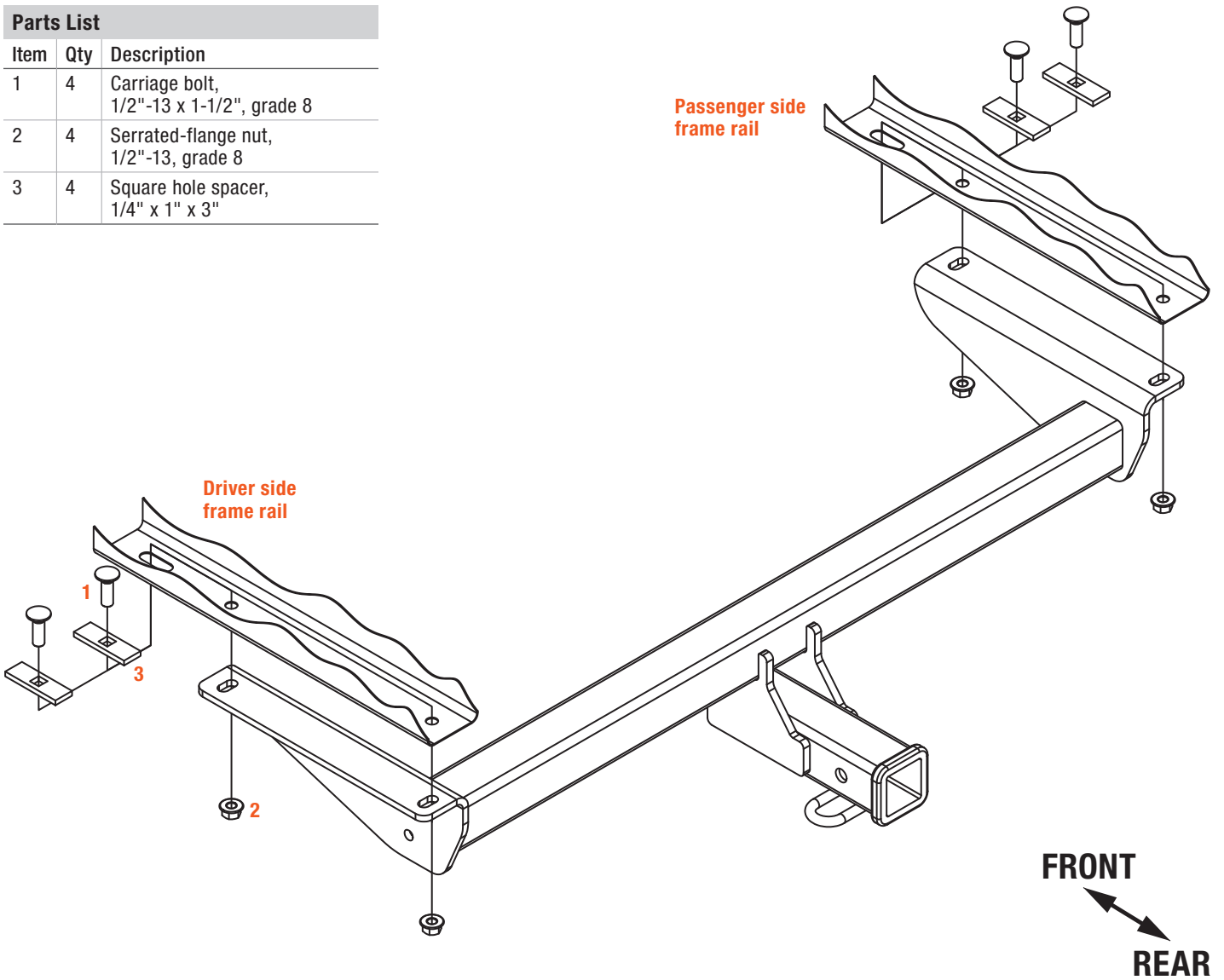

FISHWIRE TECHNIQUE

Insert coiled end of fishwire tool through hitch mounting hole in vehicle frame rail and out the access hole. Pass coiled end of fishwire through spacer and thread bolt into coil. Kink wire to keep spacer separate from bolt as shown. Pull fishwire, spacer and bolt through frame and out mounting hole. Use fishwire to guide hitch during mounting and prevent loss of bolt or spacer inside frame rail.

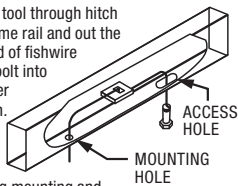

Step 1

Remove the four plastic fasteners from the fascia using a T-15 Torx bit.

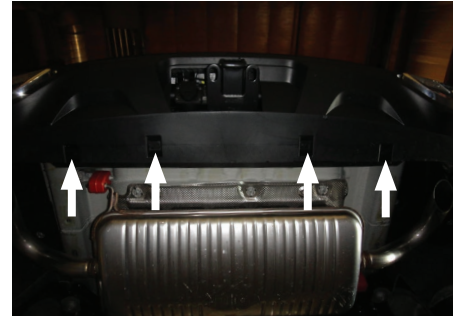
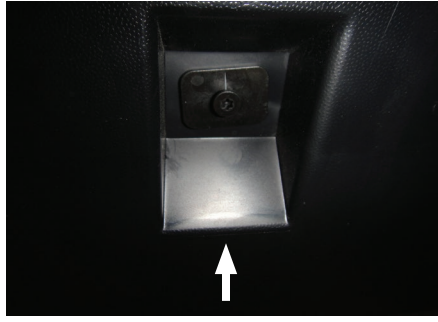

Step 2

Remove the four retainer clips from the fascia by squeezing the tabs together that secure it to the metal hanger.

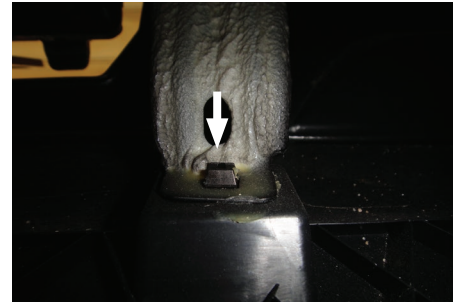

Step 3

Fishwire two 1/2" carriage bolts (#1) and square-hole spacers (#3) into the existing holes in each frame.

Note: Removal of underbody coating from access hole may be required.



Step 4

Mark and trim the fascia panel. See trim diagram for approximate dimensions.

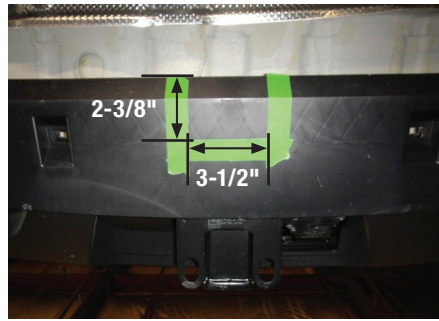

Step 5

Raise the trailer hitch into position, taking care not to knock the bolts back into frame. Secure with 1/2" serrated-flange nuts (#2).

Torque all 1/2" fasteners to 110 lb-ft.

Reinstall the retaining clips and fasteners that were removed in steps 1 and 2.



Final Installed Image



TOWING BASICS & SAFETY INFORMATION

For information on safely towing your trailer, visit curtmfg.com/understanding-towing.