

➤ Instructions

Thule Shield Pannier

3204208



EN Side mounted bag for bikes
FR Sac latéral pour vélos
ES Bolsa de montaje lateral para bicicletas
DE Seitentasche für Fahrräder
NL Enkele fietstas
PT Bolsa para bicicleta com montagem lateral
IT Borse da bici laterali
SV Sidomonterad cykelväska
DK Sidemonteret cykeltaske
NO Sideveske for sykkel
FI Sivulle kiinnitettävä polkupyörälaukku
IS Hliðartaska fyrir hjól
ET Küljele kinnitatav rattakott
LV Sānos piestiprināma soma divriteņiem
LT Dviračio šone tvirtinamas krepšys
RU Боковая сумка для велосипедов
UK Сумка з бічним кріпленням для велосипедів
PL Torba do roweru mocowana z boku
CS Cyklistická brašna s montáží na stranu
HU Oldaltáska kerékpárhoz
RO Geantă de bicicletă cu montare laterală
SK Bočný vak pre bicykle

SL Stranska torba za kolesa
BG Странична чанта за мотори
HR Bisage za bicikle
EL Τσάντα που τοποθετείται στο πλάι για ποδήλατα
TR Bisikletler için yandan takılan çanta
MT Borża mmuntata mal-ġenb għar-roti

HE תיק צד לאופניים

AR حقيبة للتعليق الجانبي على الدراجات

ZH (CN) 侧面安装的自行车包

ZH (TW) 側裝式自行車包

JA サイクル用サイド取り付けバッグ

KO 자전거용 사이드 장착 가방

TH ถุงที่ติดตั้งด้านข้างสำหรับจักรยาน

MS Beg dipasang sisi untuk basikal

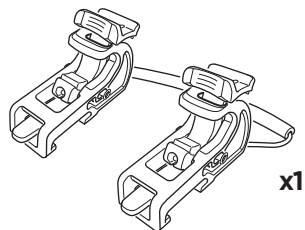
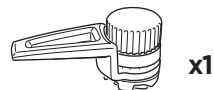
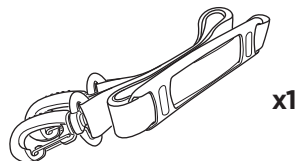
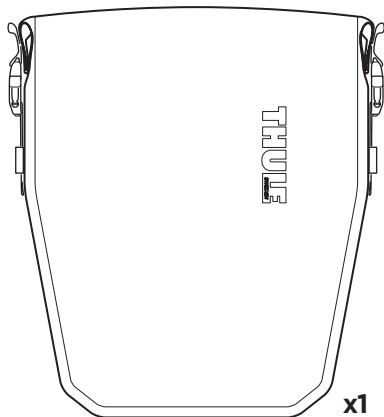

i

	Weight	Volume	Max load
3204208	1,2 kg	17 litre	9 kg



- EN** Roll top 2 times
FR Enroulez la partie supérieure 2 fois
ES Enrolle la parte superior 2 veces
DE Oberen Teil 2 Mal aufrollen
NL Rol de sluiting 2 keer om
PT Enrole a parte de cima 2 vezes
IT Ruotare la parte superiore 2 volte
SV Rulla överdelen 2 varv
DK Rul toppen 2 gange
NO Rull toppen 2 ganger
FI Rullaa yläosaa 2 kertaa
IS Efri hluti brettist 2 sinnum niður
ET Keerake ülemist osa 2 korda
LV Pagriez at augšdaļu 2 reizes
LT Viršų galima užlenkti 2 kartus
RU Прокрутите верхнюю часть 2 раза

UK Прокрутіть верхню частину 2 рази

PL Owiń górną część 2 razy

CS Horní stranu 2 krát zaviňte

HU Tekerje fel a táska tetejét 2-szer

RO Rulați de 2 ori

SK Hornú stranu 2-krát zaviňte

SL Zvijte zgornji del 2-krat

BG Навийте горната част 2 пъти

HR Presavijte gornji dio 2 puta

EL Το κάλυμμα τυλίγεται 2 φορές

TR Üst tarafı 2 kez yuvarlayın

MT Dawwar il-parti ta' fuq għal 2darbiet

HE יש לגלגל את החלק העליון 2 פעמים

AR قم باللف إلى أعلى 2 مرات

ZH (CN) 2 重卷边封口

ZH (TW) 上捲 2 次

JA 2 回転させます

KO 상단부를 2 회 접으세요

TH ม้วนเก็บได้ 2 เท่า

MS Gulung bahagian atas sebanyak 2 kali

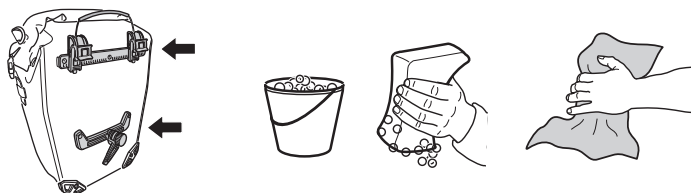

1

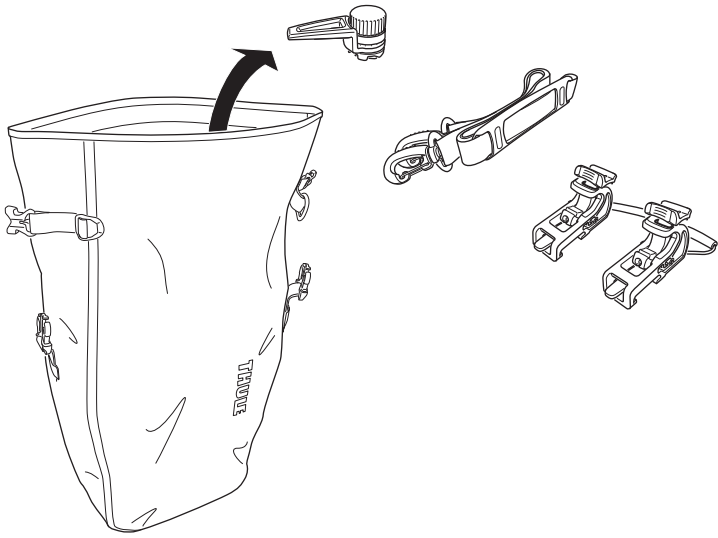

2

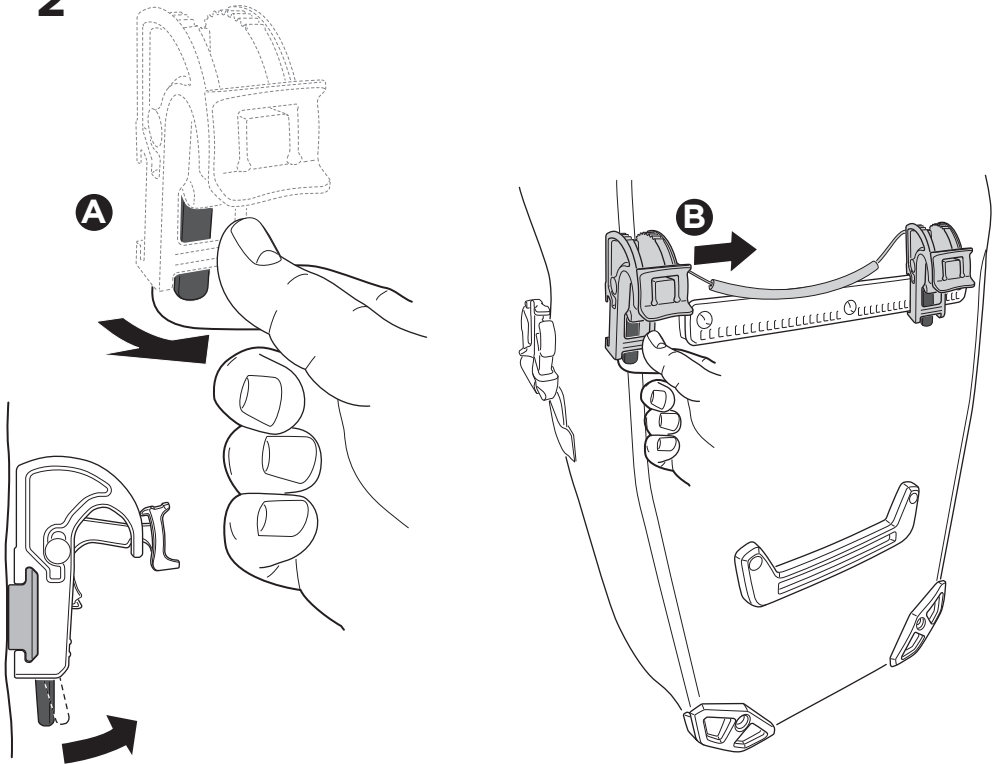

i

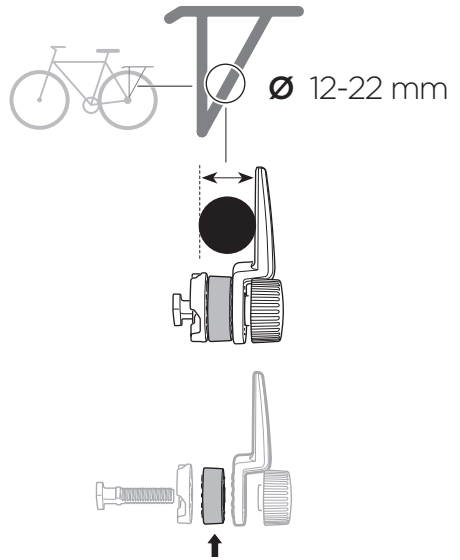
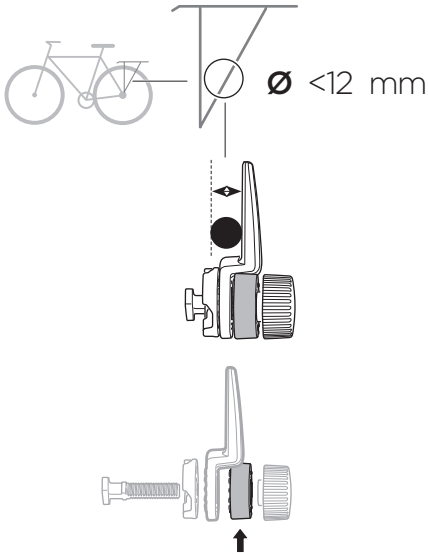

3

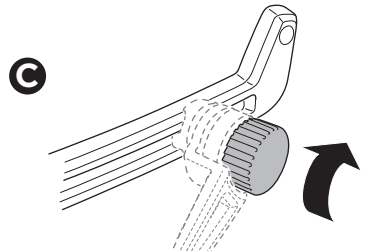
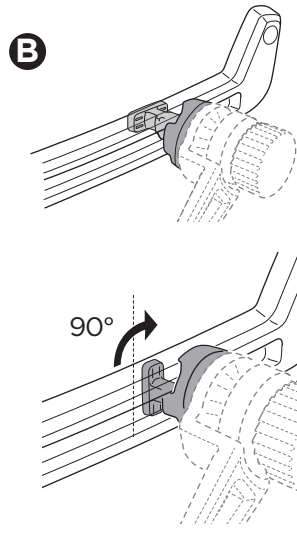
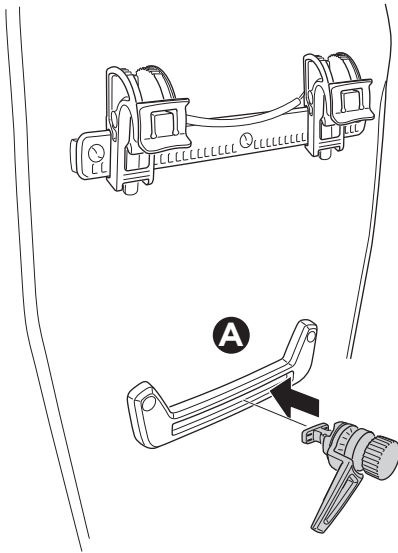

4

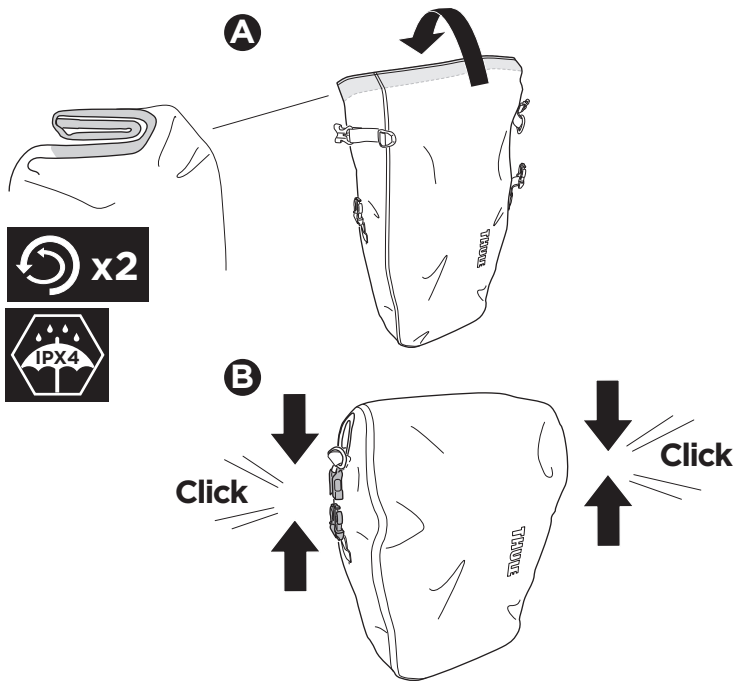

5

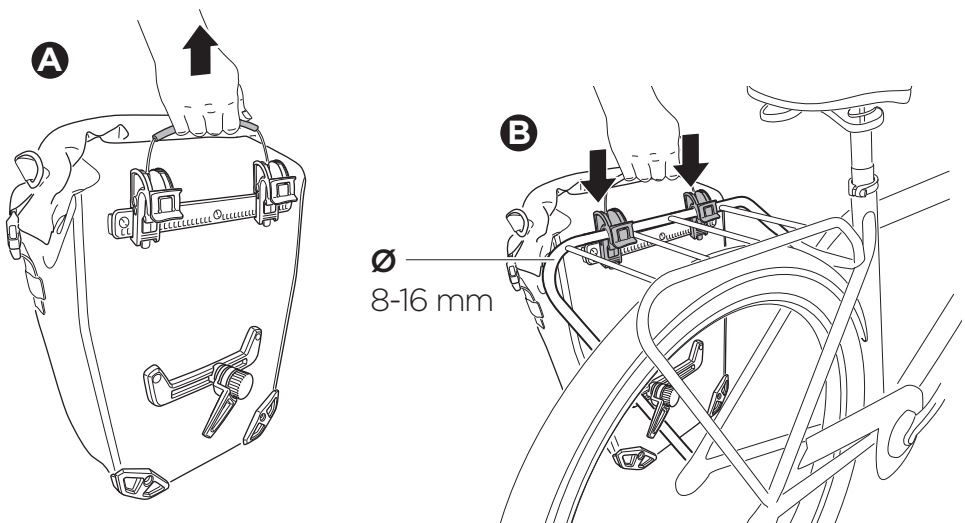
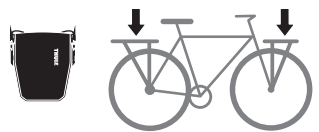

i

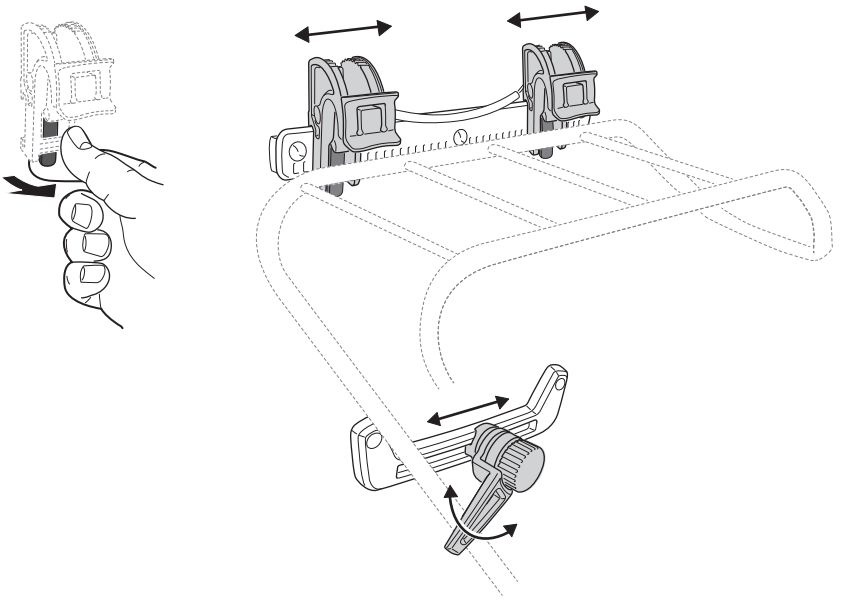

6

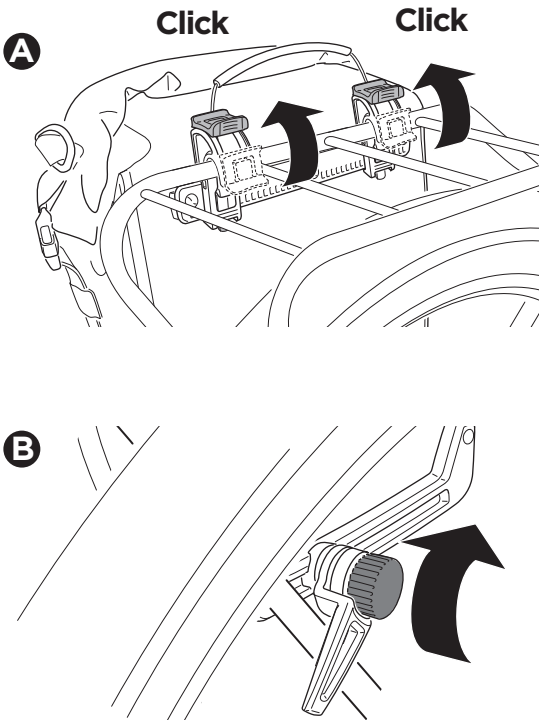

7

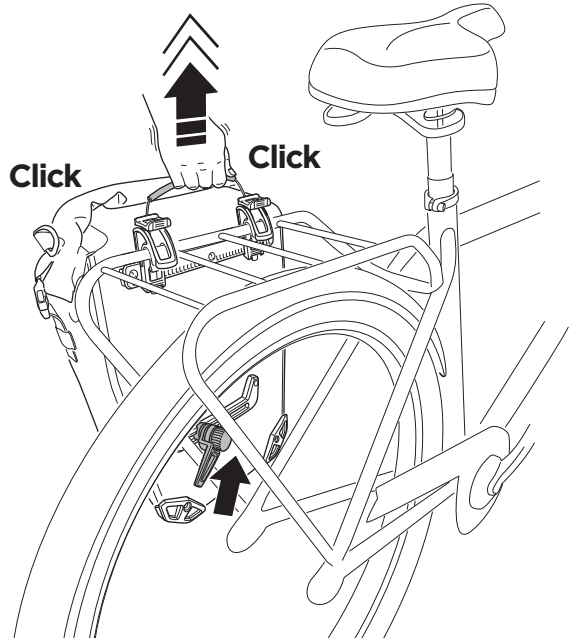
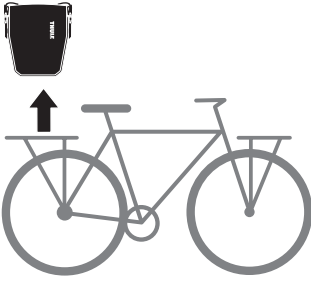

8

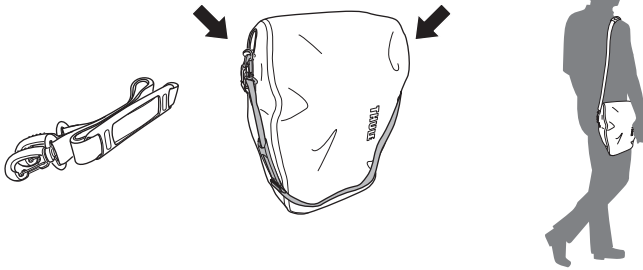

i

